



AC Series

Threaded Coupling Connectors MIL-C-5015
Commercial & QPL'd



cinch
CONNECTIVITY SOLUTIONS
a bel group

+1 305.234.1000
cinch.com

PRODUCT INDEX

AC Series

Threaded Coupling Connectors MIL-C-5015 Commercial & QPL'd

Contents

Nomenclature Guide	4	Series AC06F/MS3106F Straight Plug	26
Product Data	5	Series AC08A/MS3018A & AC08R/MS3106R 900Cable Plug	27
Insert Arrangements	6	Series AC08F/MS3108F 900 Cable Plug	28
Insert Arrangements Diagrams	7	Series AC-C Crimp Style Contacts, Commercial Version	29
Polarization	19	MS25043 Dust Caps for Receptacle Connectors (AC00/AC01/AC02	30
Series AC00A/MS3100A & AC00R/MS3100R Wall Mount Receptacle	20	MS25042 Dust Caps for Plug Connectors (AC06/AC08)	31
Series AC00F/MS3100F Wall Mount Receptacle	21	MS3057A Cable Strain Relief Clamp	32
Series AC01A/MS3101A and AC01R/MS3101R In-Line Receptacle	22	MS3057B Cable Strain Relief Clamp	33
Series AC01F/MS3101F In-Line Receptacle	23	MS3057C Cable Strain Relief Clamp	34
Series AC02A/MS3102A Box Mount Receptacle	24	Accessories - MS3420 Neoprene Sleeves and Sealing Plugs	35
Series AC06A/MS3016A and AC06R/MS3016R Straight Plug	25	Accessories - Gaskets (AC00/MS3100, AC01/MS3101 & AC02/MS3102	36

Features

Cinch Connector's "AC" Series connectors meet or exceed the requirements for qualification to MIL-C-5015 and are listed in the U.S. Government's Qualified Parts List. These connectors are available in 11 shell sizes and over 100 insert arrangements, intermateable and interchangeable with all connectors produced in accordance with MIL-C-5015. Standard contact termination utilizes solder. However, Cinch offers crimp as well as PC-tail contacts satisfying a wide range of applications and assembly methods.

Designed for wire sizes AWG 0 to 20, these highly durable connectors are used on fixed and mobile military equipment, industrial applications such as machine tools, robotic and automation equipment, and on transportation equipment including trucks, buses, trains and planes.

Shells and hardware are made of high strength aluminum alloys and are available with a variety of plated or anodized finishes. Contacts are machined from solid copper alloy and silver plated in accordance with QQ-S-365. With a standard operating temperature range of -550C to +1250C, available with a variety of accessories and features, Cinch's AC Series is widely called out by design engineers and specifiers seeking reliability and durability throughout a broad range of environmental requirements.

Cinch Connectivity Solutions produces high quality products. These products are intended to be used in accordance with the specifications described in this catalog. Any use or application that deviates from the stated operating specifications is not recommended and may be unsafe. A limited warranty is applicable. Except for obligations assumed by Cinch Connectivity Solutions under

warranty, Cinch will be not be liable for any loss, damage, repairs, incidental or consequential damages of any kind, whether or not based upon expressed or implied warranty, contract, negligence, or liability arising from the application or manufacture or repair of these products. This catalog is not a contractual offering; it is for informational purposes only.

AC Series

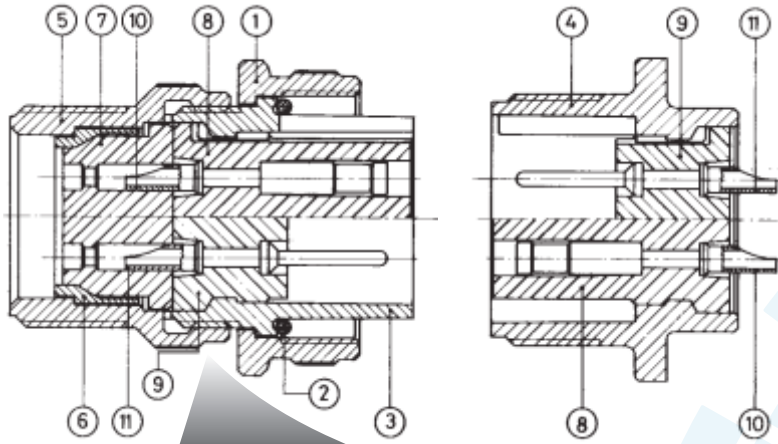

- 1) Coupling nut
- 2) Sealing casket
- 3) Insert holder
- 4) Receptacle shell
- 5) Back shell
- 6) Compression sleeve
- 7) Grommet
- 8) Socket insert
- 9) Pin insert
- 10) Socket contact
- 11) Pin contact

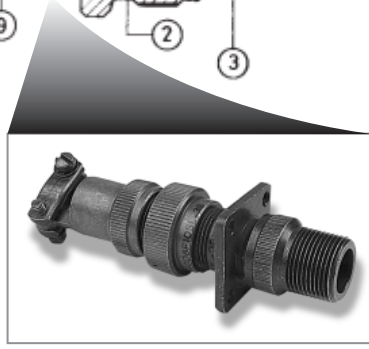

AC00/MS3100
Wall Mount Receptacle



AC01/MS3101
In-Line Receptacle



AC02/MS3102
Box Mount Receptacle



AC06/MS3106
Straight Plug



AC08/MS3108
90 Degree Cable Plug

Nomenclature Guide

Threaded MIL-C-5015 Style

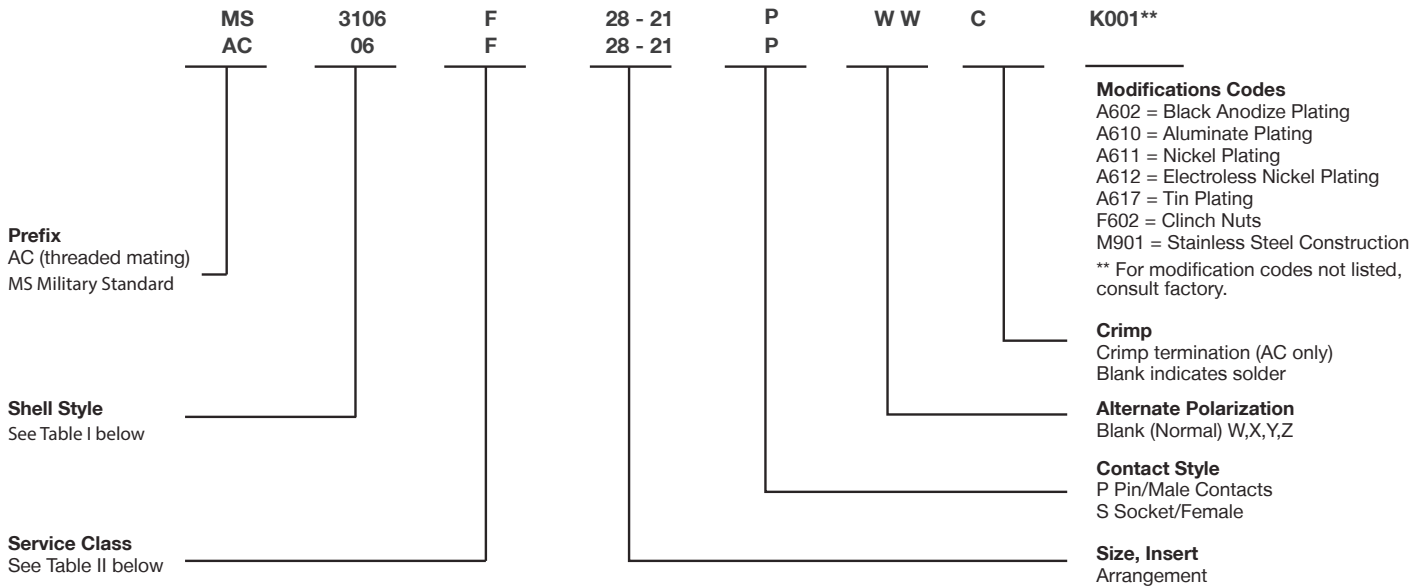

Table I. Shell Style

Cinch STYLE	MS No.	DESCRIPTION	AVAILABLE IN CLASS
00	MS3100	Wall mount receptacle	A,F,R
01	MS3101	In-line receptacle	A,F,R
02	MS3102	Box mount receptacle	A,R
06	MS3106	Straight plug	A,F,R
08	MS3108	900angle plug	A,F,R

Potting connectors available. Consult Factory.

Table II. Service Class

CLASS	DESCRIPTION
A	Solid shell, solder contacts and non-pressurized.
C	Solder contacts and pressurized, use R.
E	Environmental, use R or F.
F	R type with clamp.
R	Crimp or solder contacts with grommet seal and without clamp.

Note: All classes have OD Cadmium finish, 1250C, Aluminum shells.



Product Data

Electrical

Contact Ratings

Contact Size	Rated Current, Max Amps.	Operating Current, Amps.	Test Current, Amps.	Voltage Drop mV
16	22	13	20	21
12	41	23	35	20
8	73	46	60	12
4	135	80	110	10
0	245	150	200	10

Voltage Ratings

Class	Operating, V.D.C.	Operating, V.A.C.	Test, V RMS
I	250	200	1000
A	700	500	2000
D	1250	900	2800
E	1750	1250	3500
B	2450	1750	4500
C	4200	3000	7000

Solder Well

Contact Size	Well Diameter		Well Depth		Max Allowable Cable (AWG)
	mm.	inches	mm.	inches	
16	1.80	0.0709	6.60	0.2598	16
12	2.90	0.1142	10.0	0.3937	12
8	5.35	0.2106	13.0	0.5118	8
4	8.40	0.3307	16.0	0.6299	4
0	11.90	0.4685	16.0	0.6299	0

Standard Material and Finishes

Shell (MIL-STD)	Aluminum alloy, conductive olive drab chromate over cadmium finish per QQ-P-416. (Consult Factory for Commercial options.)
Insulator	Synthetic Rubber
Grommet and Seal	Synthetic Rubber
Contacts	Copper alloy with silver plate per QQ-S-365
Temperature Range	-550C to +1250C

Cross Reference

MIL SPEC (Notes 3 & 4)	LEADING SUPPLIERS' COMMERCIAL EQUIVALENT				
	Cinch	AMPHENOL (Note 1)	BENDIX (Note 2)	CANNON	VEAM
MS3100A-*	AC00A-*	97-3100A-*	61-1680-* or CS3100A-*	CA3100A-*	VS3100A-*
MS3100B-*	~~~~	97-3100B-*	~~~~	~~~~	~~~~
MS3100E-*	AC00E-*	69-3100E-*	10-1690-* or SG3100E-*	CA3100E-*	VS3100E-*
MS3100F-*	AC00F-*	69-3100F-*	10-4740-* or SM3100RC-*	CA3100F-*	VS3100F-*
MS3100R-*	AC00R-*	69-3100R-*	10-1900-* or SM3100R-*	CA3100R-*	VS3100R-*
MS3101A-*	AC01A-*	97-3101A-*	61-1681-* or CS3101A-*	CA3101A-*	VS3101A-*
MS3101B-*	~~~~	97-3101B-*	~~~~	CA3101B-*	~~~~
MS3101E-*	AC01E-*	69-3101E-*	10-1691-* or SG3101E-*	CA3101E-*	VS3101E-*
MS3101F-*	AC01F-*	69-3101F-*	10-4741-* or SM3101RC-*	CA3101F-*	VS3101F-*
MS3101R-*	AC01R-*	69-301R-*	10-1901-* or SM3101R-*	CA3101R-*	VS3101R-*
MS3102A-*	AC02A-*	97-3102A-*	61-1682-* or CS310A-*	CA3102A-*	VS3102A-*
MS3102E-*	AC02E-*	69-3102E-*	10-1682-* or SG3102E-*	CA3102E-*	VS3102E-*
MS3102R-*	AC02R-*	69-3102R-*	10-1902-* or SG3102R-*	CA3102R-*	VS3102R-*
MS3103-*	AC03-*	69-3103-*	10-1890-* or SC00P-*	CA3100ER-*	VS3103P-*
MS3106A-*	AC06A-*	97-3106A-*	61-1686-* or CS3106A-*	CA3106A-*	VS3106A-*
MS3106B-*	~~~~	97-3106B-*	~~~~	CA3106B-*	~~~~
MS3106E-*	AC06E-*	69-3106E-*	10-1696-* or SG3106E-*	CA3106E-*	VS3106E-*
MS3106F-*	AC06F-*	69-3106F-*	10-4746-* or SM3106RC-*	CA3106F-*	VS3106F-*
MS3106R-*	AC06R-*	69-3106R-*	10-1906-* or SM3106R-*	CA3106R-*	VS3106R-*
MS3108A-*	AC08A-*	97-3108A-*	61-1688-* or CS3108A-*	CA3108A-*	VS3108A-*
MS3108B-*	~~~~	97-3108B-*	~~~~	CA3108B-*	~~~~
MS3108E-*	AC08E-*	~~~~	10-1698-* or SG3108E-*	CA3108E-*	VS3108E-*
MS3108R-*	AC08R-*	~~~~	~~~~	CA3108R-*	VS3108R-*
MS25183-*	AC25183-*	69/97-3106-*(824)	10-3054-* or SC06P-*	CA3106ER-*	VS25183-*
MS25183A-*	AC25183A-*	97-3106-*(826)	10-4353-* or SC06P-*(G)	CA06ER-*	VS25183A-*
~~~~	ACBFR*	~~~~	~~~~	BFR*	~~~~
~~~~	ACTBF*	~~~~	~~~~	TBF*	~~~~

NOTES:

1. Amphenol part numbers prior to amphenol/Bendix merger.
2. Bendix part numbers prior Amphenol/Bendix merger. 10-, 61-, 62 prefix part numbers have been replaced by CS, SC, SG, and SM prefix part numbers.
3. MS3103 is potting receptacle (not for new design); MS25183 are plugs with potting cup. No current QPL; commercial versions only.
4. Classes A, B, C, are inactive for new design; QPL is not maintained. Class R should be used in lieu of Class C. Classes A and B can have resilient (marked "res") or hard-plastic inserts.

Insert Arrangements

INSERT	No. of contacts	Voltage class	Contact Types			
			0	4	8	16
* 10SL - 3						3
* 10SL - 4	2	A				2
* 14S - 2	4	Inst.				4
* 14S - 5	5	Inst.				5
* 14S - 6	6	Inst.				6
14S - 7	3	A				3
14S - 9	2	A				2
* 16S - 1	7	A				7
* 16S - 5	3	A				3
16 - 7	3	A		1		2
16S - 8	5	A				5
* 16 - 9	4	A			2	2
* 16 - 10	3	A				3
16 - 11	2	A				2
* 16 - 12	1	A	1			
* 18 - 1	10	A/Inst.				10
18 - 3	2	D				2
* 18 - 4	4	D				4
18 - 5	3	D				2 1
18 - 6	1	D	1			
18 - 7	1	B		1		
18 - 8	8	A			1	7
18 - 9	7	Inst.				2 5
18 - 10	4	A				4
* 18 - 11	5	A				5
18 - 12	6	A				6
18 - 13	4	A		1	3	
18 - 14	2	A	1			1
18 - 16	1	C				1
* 18 - 19	10	A				10
* 18 - 20	5	A				5
18 - 22	3	D				3
18 - 29	5	A				5
* 20 - 2	1	D	1			
20 - 3	3	D				3
* 20 - 4	4	D				4
20 - 6	3	D				3
20 - 7	8	A/D				8
* 20 - 8	6	Inst.		2		4
20 - 9	8	A/D			1	7
* 20A - 9	9	A/D				9
20 - 11	13	Inst.				13
20 - 12	2	A	1			1
20 - 14	5	A		2	3	
* 20 - 15	7	A				7
20 - 16	9	A			2	7
* 20 - 17	6	A				5 1
20 - 18	9	A				3 6
20 - 19	3	A			3	
20 - 20	4	A	1		3	
20 - 21	9	A				1 8
* 20 - 22	6	A			3	3
* 20 - 23	2	A			2	
20 - 24	4	A			2	2
20 - 27	14	A				14

INSERT	No. of contacts	Voltage class	Contact Types			
			0	4	8	16
* 20 - 29	17	A				17
20 - 33	11	A				11
* 20A - 48	19	Inst.				19
22 - 1	2	D			2	
* 22 - 2	3	D			3	
22 - 4	4	A			2 2	
22 - 5	6	D			2 4	
22 - 6	3	D			2 1	
22 - 7	1	E	1			
22 - 8	2	E				2
22 - 9	3	E				3
* 22 - 10	4	E				4
22 - 11	2	B				2
* 22 - 12	5	D			2 3	
22 - 13	5	A/D			4 1	
* 22 - 14	19	A				19
22 - 15	6	A/E			5 1	
22 - 16	9	A			3 6	
22 - 17	9	A/D			1 8	
22 - 18	8	A/D				8
* 22 - 19	14	A				14
22 - 20	9	A				9
22 - 21	3	A	1			2
* 22 - 22	4	A			4	
* 22 - 23	8	A/D				8
22 - 24	6	A/D			2 4	
* 22 - 27	9	A/D			1 8	
22 - 28	7	A				7
22 - 33	7	A/D				7
22 - 34	5	D			3 2	
* 24 - 2	7	D				7
24 - 3	7	D			2 5	
24 - 5	16	A				16
24 - 6	8	A/D				8
* 24 - 7	16	A			2 14	
24A - 7	7	D				7
* 24 - 9	2	A			2	
* 24 - 10	7	A			7	
* 24 - 11	9	A			3 6	
* 24 - 12	5	A			2 3	
24 - 013	13	A			6 7	
24 - 16	7	A/D			1 3 3	
24 - 17	5	D			2 3	
* 24 - 20	11	D			2 9	
24 - 21	10	D			1 9	
24 - 22	4	D			4	
* 24 - 27	7	E				7
* 24 - 28	24	Inst.				24
28 - 1	9	A/D			3 6	
28 - 2	14	D			2 12	
* 28 - 3	3	E			3	
28 - 4	9	D/E			2 7	
28 - 5	5	D			2 1 2	
28 - 6	3	D			3	
28 - 7	2	D			2	

INSERT	No. of	Voltage class	Contact Types			
			0	4	8	16
28 - 8	12	A/D/E			2 10	
28 - 9	12	D			6 6	
28 - 10	7	A/D		2 2	3	
* 28 - 11	22	A			4 18	
* 28 - 12	26	A				26
28 - 15	35	A				35
28 - 16	20	A				20
28 - 17	15	A/B/D				15
28 - 18	12	A/C/D/Inst.				12
28 - 19	10	A/B/D			4 6	
* 28 - 20	14	A			10 4	
* 28 - 21	37	A				37
28 - 22	6	D		3		3
* 28 - 51	12	A				12
* 28A - 63	28	A/Inst.			9 19	
* 32 - 1	5	D/E	2			3
32 - 2	5	E		3		2
* 32 - 3	9	D	1 2		2 4	
32 - 4	14	A/D				2 12
32 - 5	2	D	2			
* 32 - 6	23	A		2 3	2 16	
* 32 - 7	35	A/Inst.			7 28	
* 32 - 8	30	A			6 24	
32 - 9	14	D	2			12
32 - 10	7	A/B/D/E		2 2	3	
32 - 12	15	A/D			5 10	
32 - 13	23	D			5 18	
* 32A - 13	13	D				13
32 - 15	8	D	2			6
32 - 17	4	D		4		
32 - 31	31	A				31
36 - 1	22	D			4 18	
36 - 3	6	D		3		3
36 - 4	3	A/D		3		
* 36 - 5	4	A		4		
* 36 - 6	6	A		2 4		
* 36 - 7	47	A				7 40
36 - 8	47	A				1 46
36 - 9	31	A		1 2	14 14	
* 36 - 10	48	A				48
36 - 13	17	A/E			2 15	
36 - 14	16	D			5 5 6	
36 - 15	35	A/D				35
36 - 20	34	A			2 2 30	
* 36A - 22	22	D				22
* 36 - 54	39	A			8 31	
* 36 - 74	44	A			1 43	
* 40 - 1	30	D			6 24	
* 40 - 9	47	A			1 22 24	
* 40 - 10	29	A			4 9 16	
40 - 26	26				7 19	
* 40A - 31	31	D				31
* 40A - 35	35	D				35
* 40 - 53	60	A				60
* 40 - 56	85	A				85
40 - 63	61	A				61

(*) Currently Produced. Other Inserts, Available on Request



Insert Arrangements

The diagrams show the front insert view in normal angular position

1 CONTACT

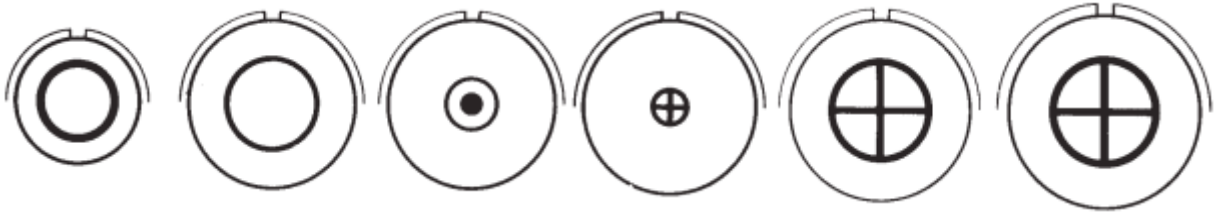

Insert arrangement	16-12	18-6	18-7	18-16	20-2	22-7
No. of contacts	1	1	1	1	1	1
Contacts size	4	4	8	12	0	0
Service rating	A	D	B	C	D	E

2 Contacts

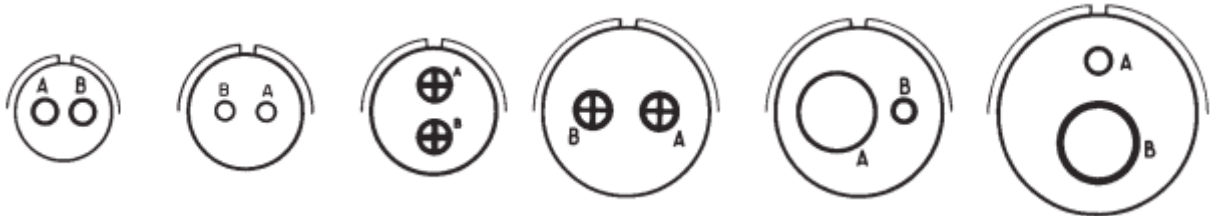

Insert arrangement	10 SL-4	14 S-9	16-11	18-3	18-14	20-12
No. of contacts	2	2	2	2	2	2
Contacts size	16	16	12	12	1-4, 1-16	1-4, 1-16
Service rating	A	A	A	D	A	A

2 Contacts

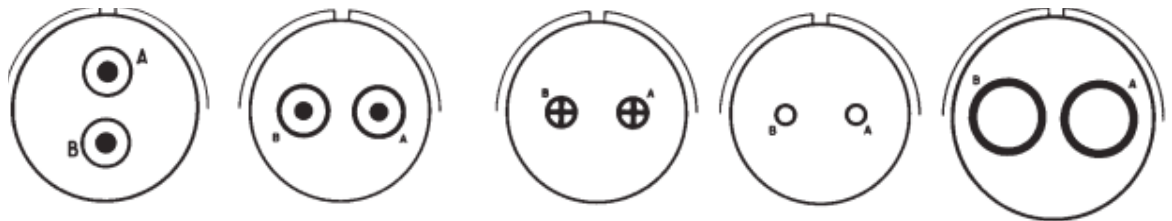

Insert arrangement	20-23	22-1	22-8	22-11	24-9
No. of contacts	2	2	2	2	2
Contacts size	8	8	12	16	4
Service rating	A	D	E	B	A

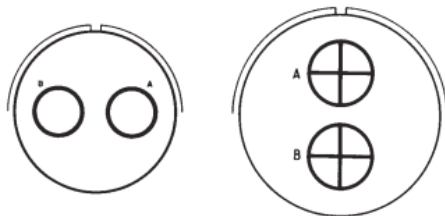

Insert arrangement	28-7	32-5
No. of contacts	2	2
Contacts size	4	0
Service rating	D	D

Contact Dimensions



The diagrams show the front insert view in normal angular position

3 Contacts

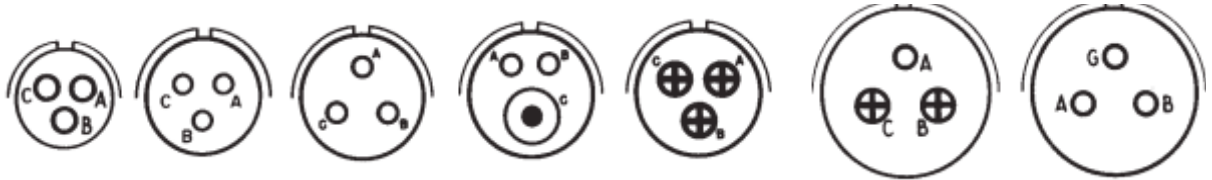

Insert arrangement	10 SL-3	14 S-7	16 S-5	16-7	16-10	18-5	18-22
No. of contacts	3	3	3	3	3	3	3
Contacts size	16	16	16	1-8, 2-16	12	2-12, 1-16	16
Service rating	A	A	A	A	A	D	D

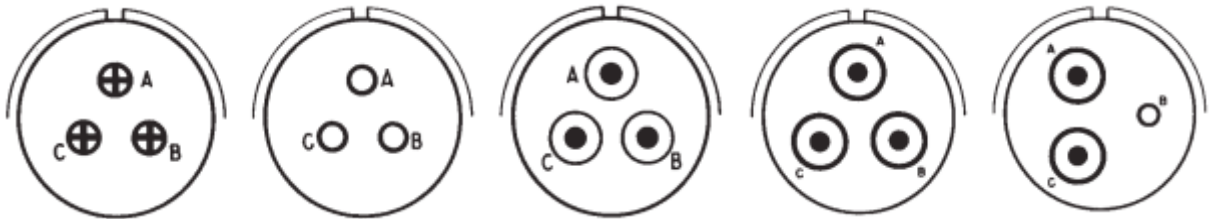

Insert arrangement	20-3	20-6	20-19	22-2	22-6
No. of contacts	3	3	3	3	3
Contacts size	12	16	8	8	2-8, 1-16
Service rating	D	D	A	D	D

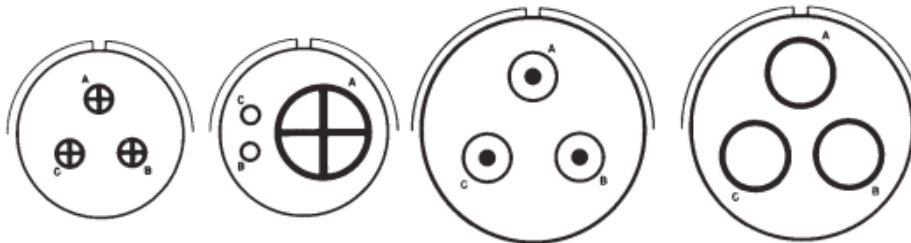

Insert arrangement	22-9	22-21	28-3	28-6
No. of contacts	3	3	3	3
Contacts size	12	1-0, 2-16	8	4
Service rating	E	A	E	D

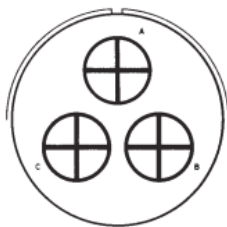

Insert Arrangement	36-4
No. of contacts	3
Contacts size	0
Service rating	A=D; B,C=A

Contact Dimensions



The diagrams show the front insert view in normal angular position

4 Contacts

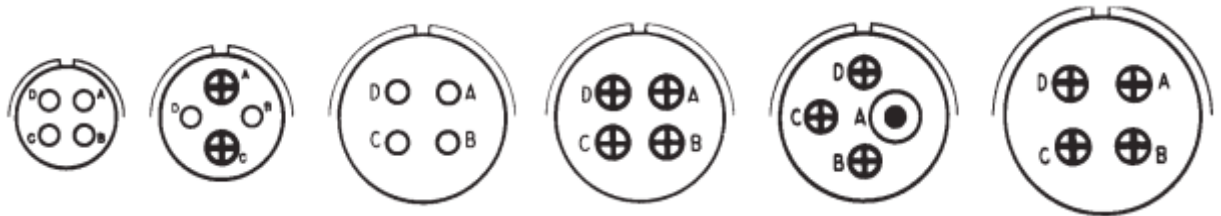

Insert arrangement	14 S-2	16-9	18-4	18-10	18-13	20-4
No. of contacts	4	4	4	4	4	4
Contacts size	16	2-12, 2-16	16	12	1-8, 3-12	12
Service rating	INST	A	D	A	A	D

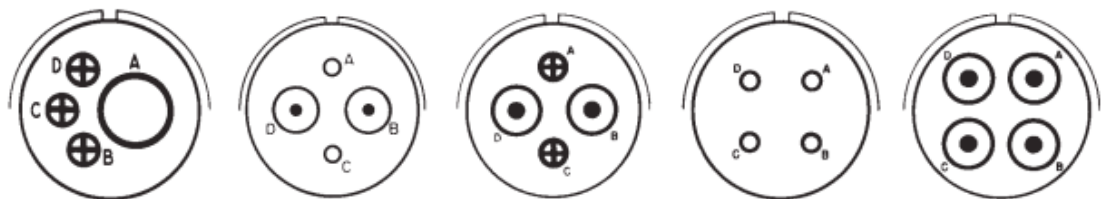

Insert arrangement	20-20	20-24	22-4	22-10	22-22
No. of contacts	4	4	4	4	4
Contacts size	1-4, 3-12	2-8, 2-16	2-8, 2-12	16	8
Service rating	A	A	A	E	A

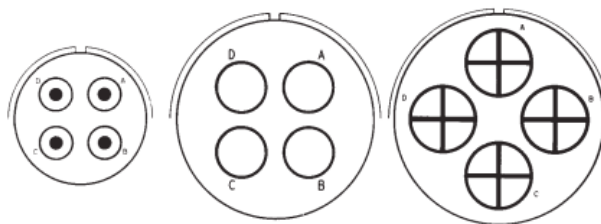

Insert arrangement	22-24	32-17	36-5
No. of contacts	4	4	4
Contacts size	8	4	0
Service rating	D	D	A

Contact Dimensions



5 Contacts

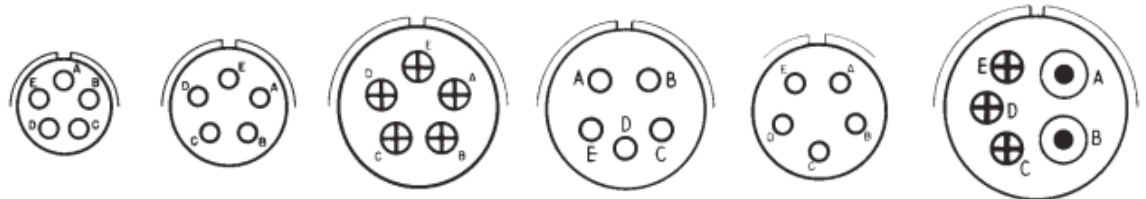

Insert arrangement	14S-5	16S-8	18-11	18-20	18-29	20-14
No. of contacts	5	5	5	5	5	5
Contacts size	16	16	16	12	16	16
Service rating	INST	A	A	A	A	A

The diagrams show the front insert view in normal angular position

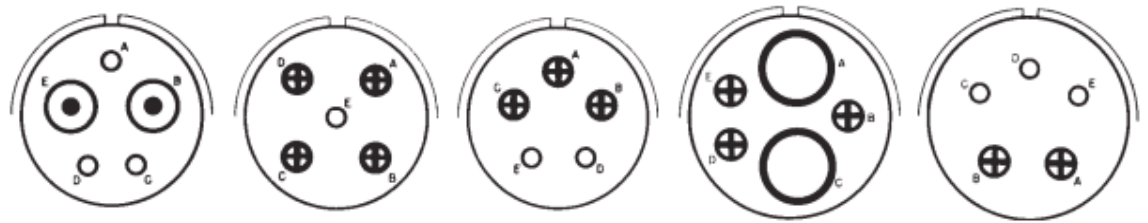

Insert arrangement	22-12	22-13	22-34	24-12	24-17
No. of contacts	5	5	5	5	5
Contacts size	2-8, 3-16	4-12, 1-16	3-12, 2-16	2-4, 3-12	2-12, 3-16
Service rating	D	E=D; A,B,C,D=A	D	A	D

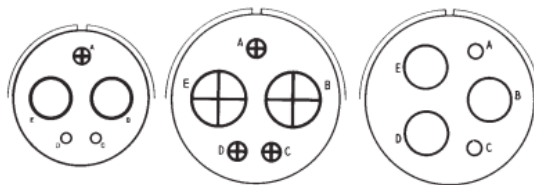

Insert arrangement	28-5	32-1	32-2
No. of contacts	5	5	5
Contacts size	2-4, 1-12, 2-16	2-0, 3-12	3-4, 2-16
Service rating	D	A=E; B,C,D,E=D	E

6 Contacts

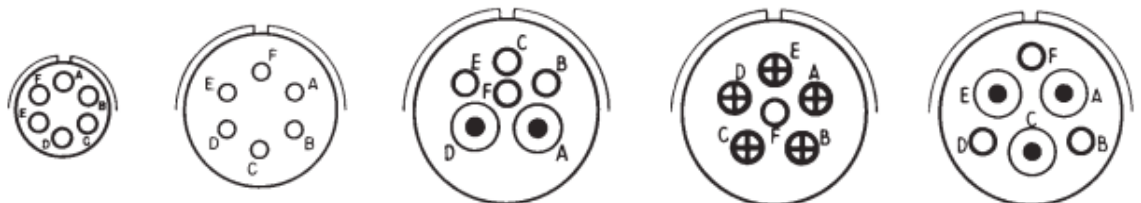

Insert arrangement	14S-6	18-12	20-8	20-17	20-22
No. of contacts	6	6	6	6	6
Contacts size	16	16	2-8, 4-16	5-12, 1-16	3-8, 3-16
Service rating	INST	A	INST	A	A

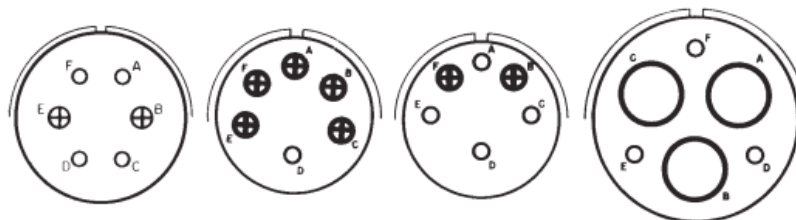

Insert arrangement	22-5	22-15	22-24	28-22
No. of contacts	6	6	6	6
Contacts size	2-12, 4-16	5-12, 1-16	2-12, 4-16	3-4, 3-16
Service rating	D	D=E; A,B,C,D,E,F=A	C,D,E=D; A,B,F=A	D

Contact Dimensions



The diagrams show the front insert view in normal angular position

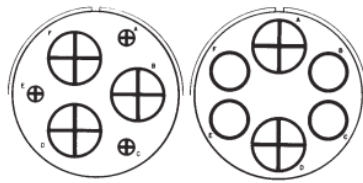

Insert arrangement	36-3	36-6
No. of contacts	6	6
Contacts size	3-0,3-12	2-0,4-4
Service rating	D	A

7 Contacts

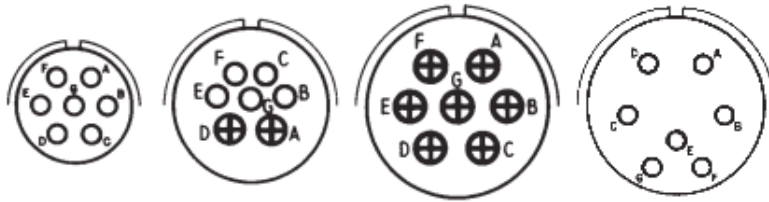

Insert arrangement	16S-1	18-9	20-15	22-33
No. of contacts	7	7	7	7
Contacts size	16	2-12, 5-16	12	16
Service rating	A	INST	A	A,B,C,D=D;E,F,G=A

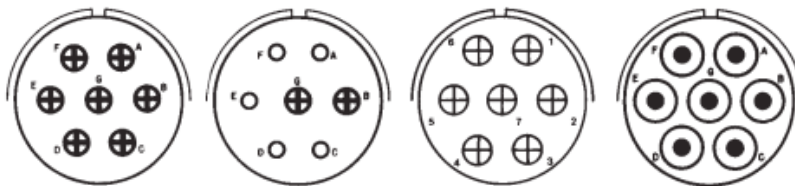

Insert arrangement	24-2	24-3	24A-7	24-10
No. of contacts	7	7	7	7
Contacts size	12	2-12,5-16	12	8
Service rating	D	D	D	A

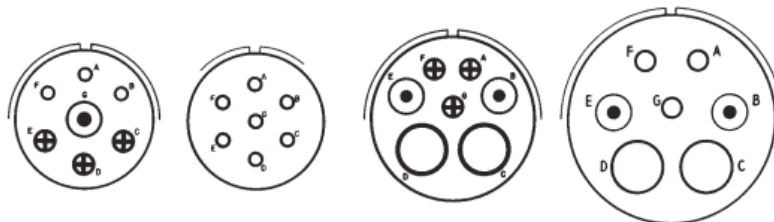

Insert arrangement	24-16	24-27	28-10	32-10
No. of contacts	7	7	7	7
Contacts size	1-8,3-12,3-16	16	2-4,2-8,3-12	2-4,2-8,3-16
Service rating	A,B,F,G=D;C,D,E=A	E	G=D;BAL.=A	A,F=E;G=B;B,E=D;C,D=A

Contact Dimensions



The diagrams show the front insert view in normal angular position

8 Contacts

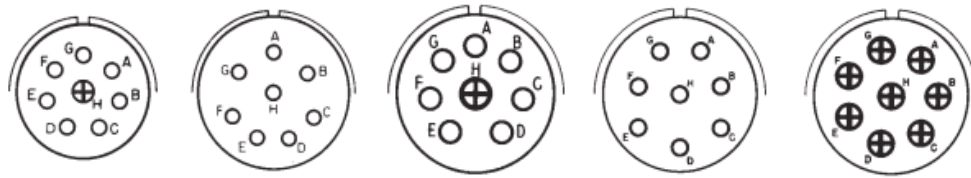

Insert arrangement	18-8	20-7	20-9	22-18	22-23
No. of contacts	8	8	8	8	8
Contacts size	1-12,7-16	16	1-12,7-16	16	12
Service rating	A	A,B,H,G=D;C,D,E,F=A	H=D;BAL=A	A,B,F,G,H=D;C,D,E=A	H=D;BAL=A

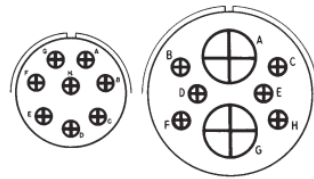

Insert arrangement	24-6	32-15
No. of contacts	8	8
Contacts size	12	2-0,6-12
Service rating	A,G,H=D;BAL=A	D

9 Contacts

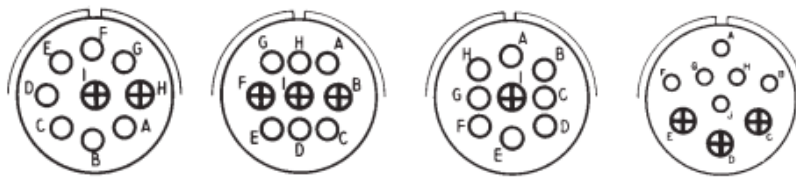

Insert arrangement	20-16	20-18	20-21	22-16
No. of contacts	9	9	9	9
Contacts size	2-12,7-16	3-12,6-16	1-12,8-16	3-12,6-16
Service rating	A	A	A	A

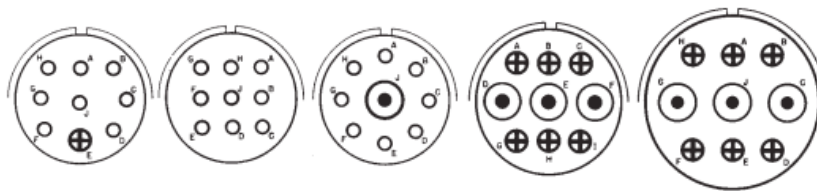

Insert arrangement	22-17	22-20	22-27	24-11	28-1
No. of contacts	9	9	9	9	9
Contacts size	1-12,8-16	16	1-8,8-16	3-8,6-12	3-8,6-12
Service rating	A=D;BAL=A	A	J=D;BAL=A	A	A,J,E=D;BAL=A

Contact Dimensions



The diagrams show the front insert view in normal angular position

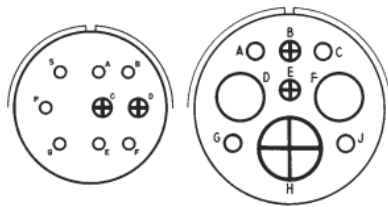

Insert arrangement	28-4	32-3
No. of contacts	9	9
Contacts size	2-12,7-16	1-0,2-4,2-12,4-16
Service rating	G,P,S=E;BAL.=D	D

10 Contacts

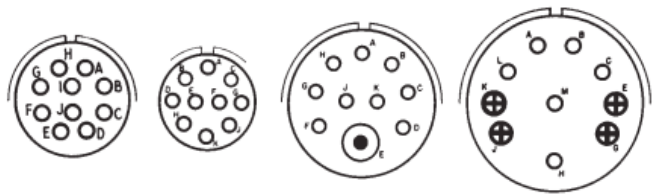

Insert arrangement	18-1	18-19	24-21	28-19
No. of contacts	10	10	10	10
Contacts size	16	16	1-8,9-16	4-12,6-16
Service rating	B,C,F,G=A;BAL.=INST	A	D	H,M=B;A,B=D,BAL.=A

11 Contacts

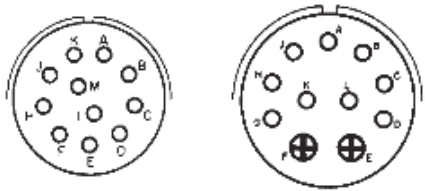

Insert arrangement	20-33	24-20
No. of contacts	11	11
Contacts size	16	2-12,9-16
Service rating	A	D

12 Contacts

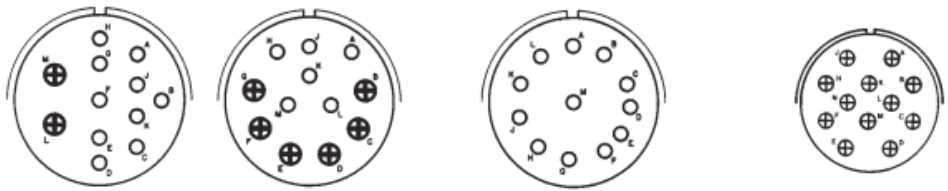

Insert arrangement	28-8	28-9	28-18	28-51
No. of contacts	12	12	12	12
Contacts size	2-12,10-16	6-12,6-16	16	12
Service rating	L,M=E;B=D;BAL.=A	D	M=C;G,H,J,K,L=D;A,B=A;BAL.=INST	A

Contact Dimensions



The diagrams show the front insert view in normal angular position

13 Contacts

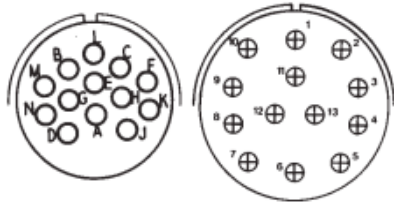

Insert arrangement	20-11	32A-13	20-27	22-19
No. of contacts	13	13	14	14
Contacts size	16	12	16	16
Service rating	INST.	D	A	A

14 Contacts

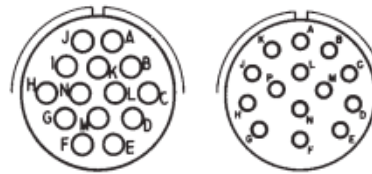

Insert arrangement	28-2	28-20	32-4
No. of contacts	14	14	14
Contacts size	2-12,12-16	10-12,4-16	2-12,12-16
Service rating	D	A	F,J,K,N=A;BAL=D

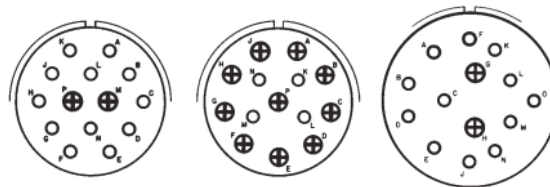

Insert arrangement	32-9
No. of contacts	14
Contacts size	2-4,12-16
Service rating	D

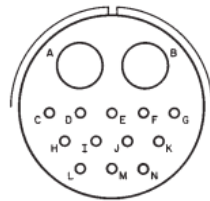

15 Contacts

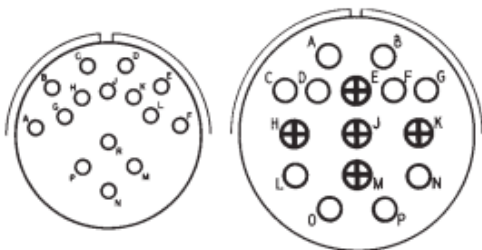

Insert arrangement	28-17	32-12
No. of contacts	15	15
Contacts size	16	5-12,10-16
Service rating	R=B;M,N,P=D;A-L=A	C,D,E,F,G=A;BAL=D

Contact Dimensions



The diagrams show the front insert view in normal angular position

16 Contacts

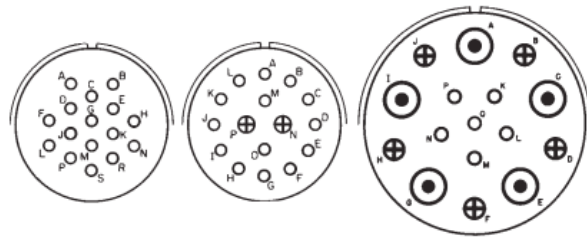

Insert arrangement	24-5	24-7	36-14
No. of contacts	16	16	16
Contacts size	16	2-12,14-16	5-8,5-12,6-16
Service rating	A	A	D

17 Contacts

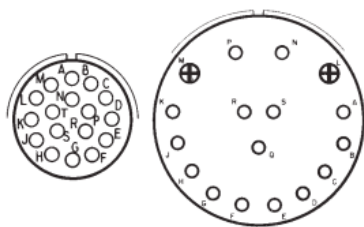

19 Contacts

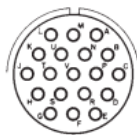

Insert arrangement	20-29	36-13	22-14
No. of contacts	17	17	19
Contacts size	16	2-12,15-16	16
Service rating	A	N,P,Q=E;BAL.=A	A

20 Contacts

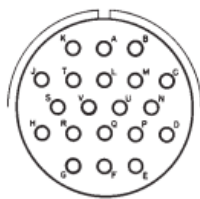

22 Contacts

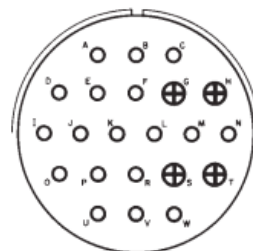
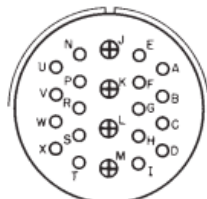

Insert arrangement	28-16	28-11	36-1
No. of contacts	20	22	22
Contacts size	16	4-12,18-16	4-12,18-16
Service rating	A	A	D

Contact Dimensions



The diagrams show the front insert view in normal angular position

22 Contacts

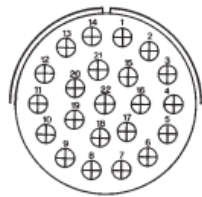

23 Contacts

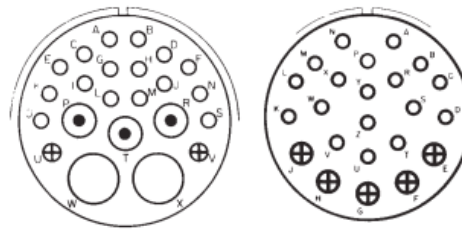

Insert arrangement	36A-22	32-6	32-13
No. of contacts	22	23	23
Contacts size	12	2-4,3-8,2-12,16-16	5-12,18-16
Service rating	D	A	D

24 Contacts

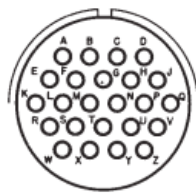

26 Contacts

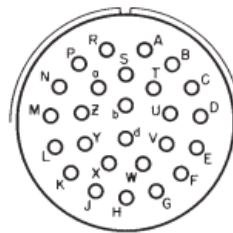

Insert arrangement	24-28	28-12
No. of contacts	24	26
Contacts size	16	16
Service rating	INST.	A

29 Contacts

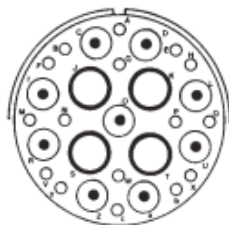

30 Contacts

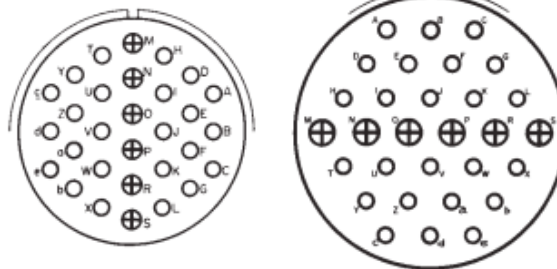

Insert arrangement	40-10	32-8	40-1
No. of contacts	29	30	30
Contacts size	4-4,9-8,16-16	6-12,24-16	6-12,24-16
Service rating	A	A	D

Contact Dimensions



The diagrams show the front insert view in normal angular position

31 Contacts

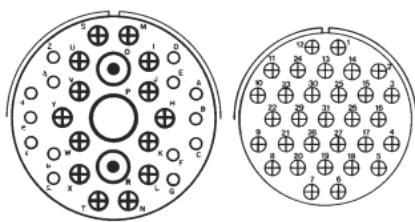

34 Contacts

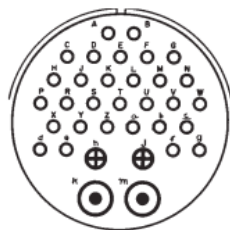

Insert arrangement	36-9	40A-31	36-20
No. of contacts	31	31	34
Contacts size	1-4,2-8,14-12,14-16	12	2-8,2-12,30-16
Service rating	A	D	A

35 Contacts

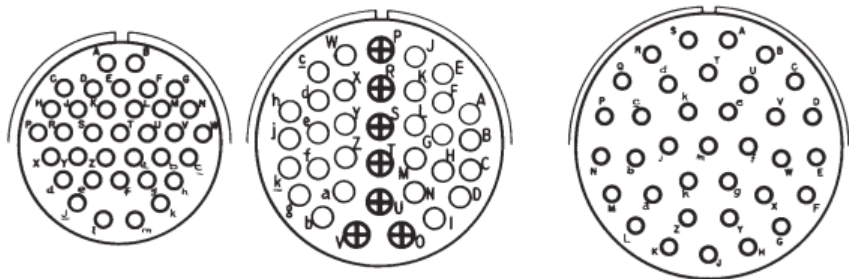

Insert arrangement	28-15	32-7	36-15
No. of contacts	35	35	35
Contacts size	16	7-12,28-16	16
Service rating	A	A,B,h,i=INST;BAL=A	M=D,BAL=A

35 Contacts

37 Contacts

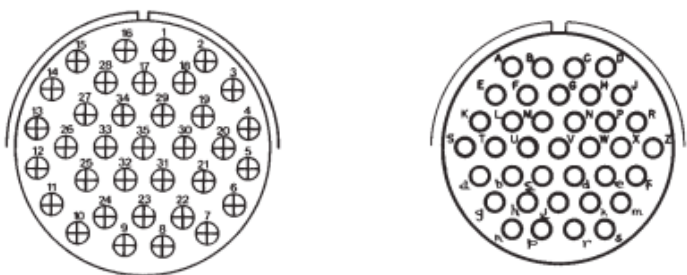

Insert arrangement	40A-35	28-21
No. of contacts	35	37
Contacts size	12	16
Service rating	D	A

Contact Dimensions



The diagrams show the front insert view in normal angular position

47 Contacts

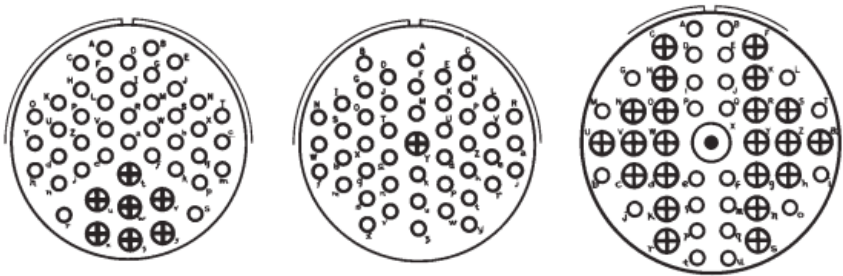

Insert arrangement	36-7	36-8	40-9
No. of contacts	47	47	47
Contacts size	7-12,40-16	1-12,46-16	1-8,22-12,24-16
Service rating	A	A	A

48 Contacts

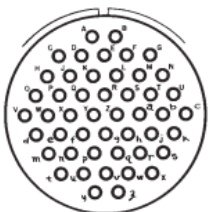

60 Contacts

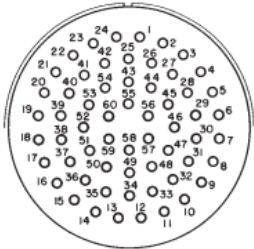

Insert arrangement	36-10	40-53
No. of contacts	48	60
Contacts size	16	16
Service rating	A	A

61 Contacts

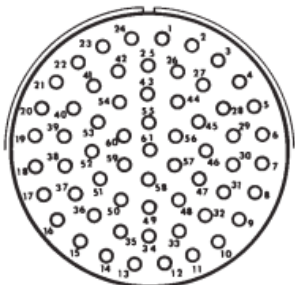

85 Contacts

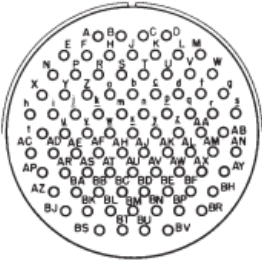

Insert arrangement	40-63	40-56
No. of contacts	61	85
Contacts size	16	16
Service rating	A	A

Contact Dimensions

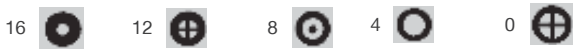

Polarization

The diagrams indicate alternate insert positions (W, X, Y, Z and Normal) and different degree of rotation for various size and layouts.

The exact angle of rotation for the combinations are listed in the table below.

normal position



INSERT	ANGULAR POS. (DEGREES)			
	W	X	Y	Z
10SL - 3	-	-	-	-
10SL - 4	-	-	-	-
14S - 2	-	120	240	-
14S - 5	-	110	-	-
14S - 6	-	-	-	-
14S - 7	90	180	270	-
14S - 9	70	145	215	290
16S - 1	80	-	-	280
16S - 5	70	145	215	290
16 - 7	80	110	250	280
16S - 8	-	170	265	-
16 - 9	35	110	250	325
16 - 10	90	180	270	-
16 - 11	35	110	250	325
16 - 12	-	-	-	-
18 - 1	70	145	215	290
18 - 3	35	110	250	325
18 - 4	35	110	250	325
18 - 5	80	110	250	280
18 - 6	-	-	-	-
18 - 7	-	-	-	-
18 - 8	70	-	-	290
18 - 9	80	110	250	280
18 - 10	-	120	240	-
18 - 11	-	170	265	-
18 - 12	80	-	-	280
18 - 13	80	110	250	280
18 - 14	80	110	250	280
18 - 16	-	-	-	-
18 - 19	-	-	-	-
18 - 20	90	180	270	-
18 - 22	70	145	215	290
18 - 29	90	180	270	-
20 - 2	-	-	-	-
20 - 3	70	145	215	290
20 - 4	45	110	250	-
20 - 6	70	145	215	290
20 - 7	80	110	250	280
20 - 8	80	110	250	280
20 - 9	80	110	250	280
20A - 9	-	110	250	-
20 - 11	-	-	-	-
20 - 12	80	110	250	280
20 - 14	80	110	250	280
20 - 15	80	-	-	280
20 - 16	80	110	250	280
20 - 17	90	180	270	-
20 - 18	35	110	250	325
20 - 19	90	180	270	-
20 - 20	80	110	250	280
20 - 21	35	110	250	325
20 - 22	80	110	250	280
20 - 23	35	110	250	325
20 - 24	35	110	250	325
20 - 27	35	110	250	325
20 - 29	80	-	-	280

INSERT	ANGULAR POS. (DEGREES)			
	W	X	Y	Z
20 - 33	-	-	-	-
20A - 48	-	80	280	-
22 - 1	35	110	250	325
22 - 2	70	145	215	290
22 - 4	35	110	250	325
22 - 5	35	110	250	325
22 - 6	80	120	250	280
22 - 7	-	-	-	-
22 - 8	35	110	250	325
22 - 9	70	145	215	290
22 - 10	35	110	250	325
22 - 11	35	110	250	325
22 - 12	80	110	250	280
22 - 13	35	110	250	325
22 - 14	80	110	250	280
22 - 15	80	110	250	280
22 - 16	80	110	250	280
22 - 17	80	110	250	280
22 - 18	80	110	250	280
22 - 19	80	110	250	280
22 - 20	35	110	250	325
22 - 21	80	110	250	280
22 - 22	-	110	250	-
22 - 23	35	-	250	-
22 - 24	80	110	250	280
22 - 27	80	-	250	280
22 - 28	80	-	-	280
22 - 33	80	110	250	280
22 - 34	80	110	250	280
24 - 2	80	-	-	280
24 - 3	80	110	250	280
24 - 5	80	110	250	280
24 - 6	-	110	250	280
24 - 7	80	110	250	280
24A - 7	80	-	-	280
24 - 9	35	110	250	325
24 - 10	80	-	-	280
24 - 11	35	110	250	325
24 - 12	80	110	250	280
24 - 013	-	-	-	-
24 - 16	80	110	250	280
24 - 17	80	110	250	280
24 - 20	80	110	250	280
24 - 21	80	110	250	280
24 - 22	45	110	250	-
24 - 27	80	-	-	280
24 - 28	80	110	250	280
28 - 1	80	110	250	280
28 - 2	35	110	250	325
28 - 3	70	145	215	290
28 - 4	80	110	250	280
28 - 5	35	110	250	325
28 - 6	70	145	215	290
28 - 7	35	110	250	325
28 - 8	80	110	250	280

INSERT	ANGULAR POS. (DEGREES)			
	W	X	Y	Z
28 - 9	80	110	250	280
28 - 10	80	110	250	280
28 - 11	80	110	250	280
28 - 12	90	180	270	-
28 - 15	80	110	250	280
28 - 16	80	110	250	280
28 - 17	80	110	250	280
28 - 18	70	145	215	290
28 - 19	80	110	250	280
28 - 20	80	110	250	280
28 - 21	80	110	250	280
28 - 22	70	145	215	290
28 - 51	80	135	195	-
28A - 63	-	110	250	-
32 - 1	80	110	250	280
32 - 2	70	145	215	290
32 - 3	80	110	250	280
32 - 4	80	110	250	280
32 - 5	35	110	250	325
32 - 6	80	110	250	280
32 - 7	80	125	235	280
32 - 8	80	125	235	280
32 - 9	80	110	250	280
32 - 10	80	110	250	280
32 - 12	80	110	250	280
32 - 13	80	110	250	280
32A - 13	65	130	230	295
32 - 15	35	110	250	280
32 - 17	45	110	250	-
32 - 31	-	-	-	-
36 - 1	80	110	250	280
36 - 3	70	145	215	290
36 - 4	70	145	215	290
36 - 5	-	120	240	-
36 - 6	35	110	250	325
36 - 7	80	110	250	280
36 - 8	80	125	235	280
36 - 9	80	125	235	280
36 - 10	80	125	235	280
36 - 13	80	110	250	280
36 - 14	90	180	270	-
36 - 15	60	125	245	305
36 - 20	-	-	-	-
36A - 22	80	110	250	280
36 - 54	-	-	-	-
36 - 74	-	-	-	-
40 - 1	65	130	235	300
40 - 9	65	125	225	310
40 - 10	65	125	225	310
40 - 26	-	-	-	-
40A - 31	80	110	250	280
40A - 35	70	130	230	290
40 - 53	-	-	-	-
40 - 56	72	144	216	288
40 - 63	-	-	-	-

Series AC00A/MS3100A

Series AC00R/MS3100R Wall Mount Receptacle

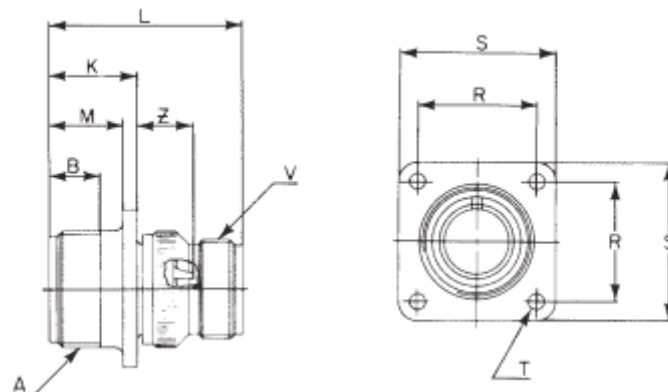

Dimensions in Inches

SHELL SIZE	A Thread Class 2A	B min.	K ± .008	L ± .020	M ± .008	R ± .004	S ± .008	T ± .004	V Thread Class 2A	Z* ± .060
10SL	.625-24 UNEF	.394	.677	1.575	.567	.717	1.000	.126	.625-24 UNEF	0.427
14S	.875-20 UNEF	.394	.693	1.575	.567	.906	1.181	.126	.750-20 UNEF	0.411
16S	1.000-20 UNEF	.394	.693	1.575	.567	.969	1.280	.126	.875-20 UNEF	0.411
16	1.000-20 UNEF	.638	.882	2.016	.756	.969	1.280	.126	.875-20 UNEF	0.650
18	1.125-18 UNEF	.638	.909	2.016	.756	1.063	1.378	.126	1.000-20 UNEF	0.622
20	1.250-18 UNEF	.638	.909	2.016	.756	1.157	1.496	.126	1.875-18 UNE	0.622
22	1.375-18 UNEF	.638	.909	2.016	.756	1.252	1.614	.126	1.875-18 UNE	0.622
24	1.500-18 UNEF	.638	.972	2.067	.819	1.374	1.752	.146	1.4375-18 UNE	0.559
28	1.750-18 UNS	.638	.972	2.382	.819	1.563	2.000	.146	1.4375-18 UNE	0.559
32	2.000-18 UNS	.689	1.035	2.516	.882	1.752	2.244	.169	1.750-18 UNS	0.496
36	2.250-16 UN	.689	1.035	2.642	.882	1.937	2.500	.169	2.000-18 UNS	0.496
40	2.500-16 UN	.689	1.035	2.642	.882	1.937	2.500	.169	2.250-16 UN	0.496

When insert includes A size "O" contact, increase "Z" by .315 inch.

Dimensions in Millimeters

SHELL SIZE	A Thread Class 2A	B min.	K ± .2	L ± .5	M ± .2	R ± .1	S ± .2	T ± .1	V Thread Class 2A	Z* ± 1.5
10SL	.625-24 UNEF	10.0	17.2	40.0	14.4	18.2	25.4	3.2	.625-24 UNEF	10.85
14S	.875-20 UNEF	10.0	17.6	40.0	14.4	23.0	30.0	3.2	.750-20 UNEF	10.45
16S	1.000-20 UNEF	10.0	17.6	40.0	14.4	24.6	32.5	3.2	.875-20 UNEF	10.45
16	1.000-20 UNEF	16.2	22.4	51.2	19.2	24.6	32.5	3.2	.875-20 UNEF	16.50
18	1.125-18 UNEF	16.2	23.1	51.2	19.2	27.0	35.0	3.2	1.000-20 UNEF	15.80
20	1.250-18 UNEF	16.2	23.1	51.2	19.2	29.4	38.0	3.2	1.1875-18 UNE	15.80
22	1.375-18 UNEF	16.2	23.1	51.2	19.2	31.8	41.0	3.2	1.1875-18 UNE	15.80
24	1.500-18 UNEF	16.2	24.7	52.5	20.8	34.9	44.5	3.7	1.4375-18 UNE	14.20
28	1.750-18 UNS	16.2	24.7	60.5	20.8	39.7	50.8	3.7	1.4375-18 UNE	14.20
32	2.000-18 UNS	17.5	26.3	63.9	22.4	44.5	57.0	4.3	1.750-18 UNS	12.60
36	2.250-16 UN	17.5	26.3	67.1	22.4	49.2	63.5	4.3	2.000-18 UNS	12.60
40	2.500-16 UN	17.5	26.3	67.1	22.4	55.6	70.2	4.3	2.250-16 UN	12.60

When insert includes A size "O" contact, increase "Z" by 8mm.



Series AC00F/MS3100F Wall Mount Receptacle

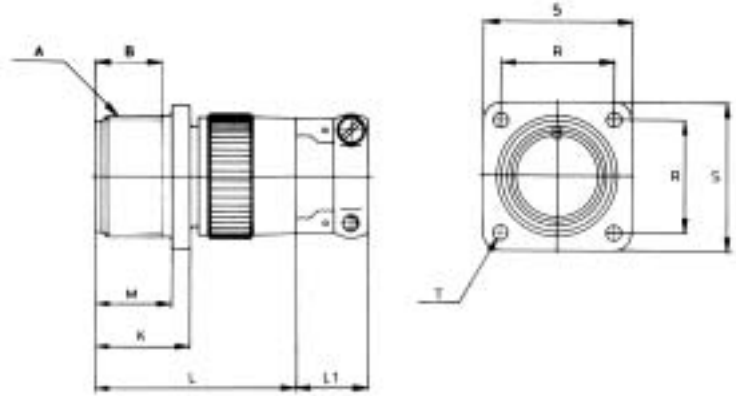
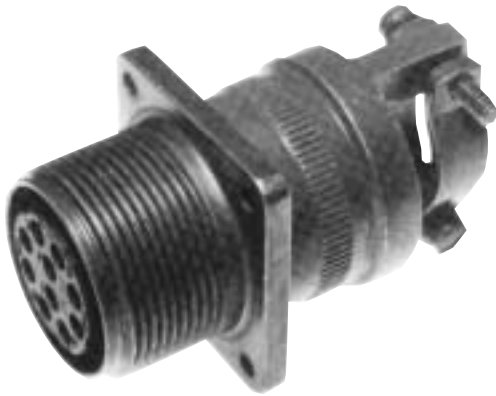

Dimensions in Inches

SHELL SIZE	A Thread Class 2A	B min.	K± .008	L± .020	L1 ± .008	M± .008	R± .004	S ± .008	T± .004
10SL	.625-24 UNEF	.394	.677	1.575	.520	.567	.717	1.000	.126
14S	.875-20 UNEF	.394	.693	1.575	.520	.567	.906	1.181	.126
16S	1.000-20 UNEF	.394	.693	1.575	.520	.567	.969	1.280	.126
16	1.000-20 UNEF	.638	.882	1.976	.531	.756	.969	1.280	.126
18	1.125-18 UNEF	.638	.909	1.957	.669	.756	1.063	1.378	.126
20	1.250-18 UNEF	.638	.909	1.957	.669	.756	1.157	1.496	.126
22	1.375-18 UNEF	.638	.909	1.957	.669	.756	1.252	1.614	.126
24	1.500-18 UNEF	.638	.972	2.067	.768	.819	1.374	1.752	.146
28	1.750-18 UNS	.638	.972	2.185	.768	.819	1.563	2.000	.146
32	2.000-18 UNS	.689	1.035	2.189	.768	.882	1.752	2.244	.169
36	2.250-16 UN	.689	1.035	2.071	1.083	.882	1.937	2.500	.169

Dimensions in Millimeters

SHELL SIZE	A Thread Class 2A	B min.	K± .2	L± .5	L1 ± .2	M± .2	R± .1	S ± .2	T± .1
10SL	.625-24 UNEF	10.0	17.2	40.0	13.2	14.4	18.2	25.4	3.2
14S	.875-20 UNEF	10.0	17.6	40.0	13.2	14.4	23.0	30.0	3.2
16S	1.000-20 UNEF	10.0	17.6	40.0	13.2	14.4	24.6	32.5	3.2
16	1.000-20 UNEF	16.2	22.4	50.2	13.5	19.2	24.6	32.5	3.2
18	1.125-18 UNEF	16.2	23.1	49.7	17.0	19.2	27.0	35.0	3.2
20	1.250-18 UNEF	16.2	23.1	49.7	17.0	19.2	29.4	38.0	3.2
22	1.375-18 UNEF	16.2	23.1	49.7	17.0	19.2	31.8	41.0	3.2
24	1.500-18 UNEF	16.2	24.7	52.5	19.5	20.8	34.9	44.5	3.7
28	1.750-18 UNS	16.2	24.7	55.5	19.5	20.8	39.7	50.8	3.7
32	2.000-18 UNS	17.5	26.3	55.6	19.5	22.4	44.5	57.0	4.3
36	2.250-16 UN	17.5	26.3	52.6	27.5	22.4	49.2	63.5	4.3
40	2.500-16 UN	17.5	26.3	52.6	27.5	22.4	55.6	70.2	4.3

+1 305.234.1000
cinch.com

Series AC01A/MS3101A

Series AC01R/MS3101R In-Line Receptacle

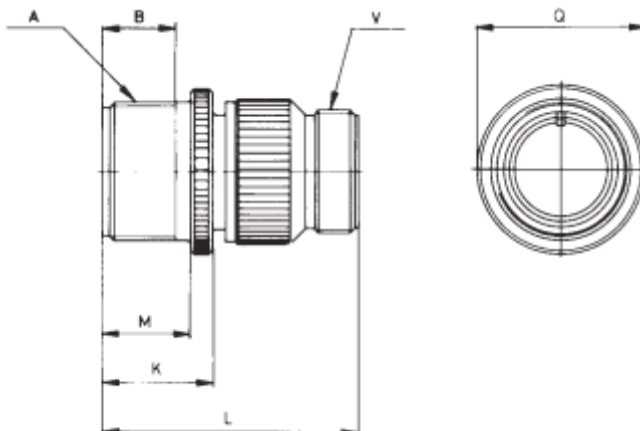

Dimensions in Inches

SHELL SIZE	A Thread Class 2A	Bmin.	K± .008	L ± .020	M± .008	Q± .020	V Thread Class 2A
10SL	.625-24 UNEF	.394	.677	1.575	.567	.976	.625-24 UNEF
14S	.875-20 UNEF	.394	.693	1.575	.567	1.165	.750-20 UNEF
16S	1.000-20 UNEF	.394	.693	1.575	.567	1.260	.875-20 UNEF
16	1.000-20 UNEF	.638	.882	2.016	.756	1.260	.875-20 UNEF
18	1.125-18 UNEF	.638	.909	2.016	.756	1.343	1.000-20 UNEF
20	1.250-18 UNEF	.638	.909	2.016	.756	1.500	1.1875-18 UNEF
22	1.375-18 UNEF	.638	.909	2.016	.756	1.622	1.1875-18 UNEF
24	1.500-18 UNEF	.638	.972	2.067	.819	1.764	1.4375-18 UNEF
28	1.750-18 UNS	.638	.972	2.382	.819	2.012	1.4375-18 UNEF
32	2.000-18 UNS	.689	1.035	2.516	.882	2.256	1.750-18 UNS
36	2.250-16 UN	.689	1.035	2.642	.882	2.512	2.000-18 UNS
40	2.500-16 UN	.689	1.035	2.642	.882	2.776	2.250-16 UN

Dimensions in Millimeters

SHELL SIZE	A Thread Class 2A	Bmin.	K± .2	L ± .5	M± .2	Q± .5	V Thread Class 2A
10SL	.625-24 UNEF	10.0	17.2	40.0	14.4	24.8	.625-24 UNEF
14S	.875-20 UNEF	10.0	17.6	40.0	14.4	29.6	.750-20 UNEF
16S	1.000-20 UNEF	10.0	17.6	40.0	14.4	32.0	.875-20 UNEF
16	1.000-20 UNEF	16.2	22.4	51.2	19.2	32.0	.875-20 UNEF
18	1.125-18 UNEF	16.2	23.1	51.2	19.2	34.1	1.000-20 UNEF
20	1.250-18 UNEF	16.2	23.1	51.2	19.2	38.1	1.1875-18 UNEF
22	1.375-18 UNEF	16.2	23.1	51.2	19.2	41.2	1.1875-18 UNEF
24	1.500-18 UNEF	16.2	24.7	52.5	20.8	44.8	1.4375-18 UNEF
28	1.750-18 UNS	16.2	24.7	60.5	20.8	51.1	1.4375-18 UNEF
32	2.000-18 UNS	17.5	26.3	63.9	22.4	57.3	1.750-18 UNS
36	2.250-16 UN	17.5	26.3	67.1	22.4	63.8	2.000-18 UNS
40	2.500-16 UN	17.5	26.3	67.1	22.4	70.5	2.250-16 UN



Series AC01F/MS3101F In-Line Receptacle

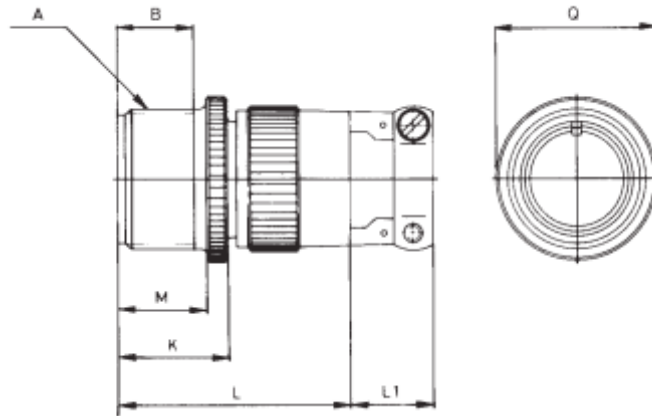

Dimensions in Inches

SHELL SIZE	A Thread Class 2A	Bmin.	K ± .008	L ± .020	L1 ± .008	M ± .008	Q ± .020
10SL	.625-24 UNEF	.394	.677	1.575	.520	.567	.976
14S	.875-20 UNEF	.394	.693	1.575	.520	.567	1.165
16S	1.000-20 UNEF	.394	.693	1.575	.520	.567	1.260
16	1.000-20 UNEF	.638	.882	1.976	.531	.756	1.260
18	1.125-18 UNEF	.638	.909	1.957	.669	.756	1.343
20	1.250-18 UNEF	.638	.909	1.957	.669	.756	1.500
22	1.375-18 UNEF	.638	.909	1.957	.669	.756	1.622
24	1.500-18 UNEF	.638	.972	2.067	.768	.819	1.764
28	1.750-18 UNS	.638	.972	2.185	.768	.819	2.012
32	2.000-18 UNS	.689	1.035	2.189	.768	.882	2.256
36	2.250-16 UN	.689	1.035	2.071	1.083	.882	2.512
40	2.500-16 UN	.689	1.035	2.071	1.083	.882	2.776

Dimensions in Millimeters

SHELL SIZE	A Thread Class 2A	Bmin.	K ± .2	L ± .5	L1 ± .2	M ± .2	Q ± .5
10SL	.625-24 UNEF	10.0	17.2	40.0	13.2	14.4	24.8
14S	.875-20 UNEF	10.0	17.6	40.0	13.2	14.4	29.6
16S	1.000-20 UNEF	10.0	17.6	40.0	13.2	14.4	32.0
16	1.000-20 UNEF	16.2	22.4	50.2	13.5	19.2	32.0
18	1.125-18 UNEF	16.2	23.1	49.7	17.0	19.2	34.1
20	1.250-18 UNEF	16.2	23.1	49.7	17.0	19.2	38.1
22	1.375-18 UNEF	16.2	23.1	49.7	17.0	19.2	41.2
24	1.500-18 UNEF	16.2	24.7	52.5	19.5	20.8	44.8
28	1.750-18 UNS	16.2	24.7	55.5	19.5	20.8	51.1
32	2.000-18 UNS	17.5	26.3	55.6	19.5	22.4	57.3
36	2.250-16 UN	17.5	26.3	52.6	27.5	22.4	63.8
40	2.500-16 UN	17.5	26.3	52.6	27.5	22.4	70.5

Series AC02A/MS3102A

Series AC02R/MS3102R Box Mount Receptacle

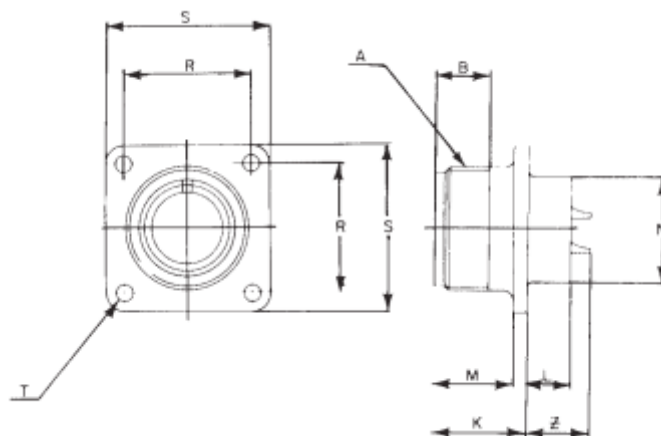

Dimensions in Inches

SHELL SIZE	A Thread Class 2A	B min.	K + .008	L + .004	M + .004	N + .004	R+ .004	S + .008	T + .004	Z* + .059
10SL	.625-24 UNEF	.394	.677	.295	.567	.630	.717	1.000	.126	.427
14S	.875-20 UNEF	.394	.693	.280	.567	.754	.906	1.181	.126	.411
16S	1.000-20 UNEF	.394	.693	.280	.567	.880	.969	1.280	.126	.411
16	1.000-20 UNEF	.638	.882	.476	.756	.880	.969	1.280	.126	.650
18	1.125-18 UNEF	.638	.909	.449	.756	1.008	1.063	1.378	.126	.622
20	1.250-18 UNEF	.638	.909	.449	.756	1.130	1.157	1.496	.126	.622
22	1.375-18 UNEF	.638	.909	.449	.756	1.256	1.252	1.614	.126	.622
24	1.500-18 UNEF	.638	.972	.437	.819	1.382	1.374	1.752	.146	.559
28	1.750-18 UNS	.638	.972	.437	.819	1.630	1.563	2.000	.146	.559
32	2.000-18 UNS	.689	1.035	.437	.882	1.880	1.752	2.244	.169	.496
36	2.250-16 UN	.689	1.035	.437	.882	2.067	1.937	2.500	.169	.496
40	2.500-16 UN	.689	1.035	.437	.882	2.317	2.189	2.764	.169	.496

When insert includes A size "O" contact, increase "Z" by .315 inch.

Dimensions in Millimeters

SHELL SIZE	A Thread Class 2A	B min.	K + .2	L + .1	M + .1	N + .1	R+ .1	S + .2	T + .1	Z* + 1.5
10SL	.625-24 UNEF	10.0	17.2	7.5	14.4	16.0	18.2	25.4	3.2	10.85
14S	.875-20 UNEF	10.0	17.6	7.1	14.4	19.15	23.0	30.0	3.2	10.45
16S	1.000-20 UNEF	10.0	17.6	7.1	14.4	22.35	24.6	32.5	3.2	10.45
16	1.000-20 UNEF	16.2	22.4	12.1	19.2	22.35	24.6	32.5	3.2	16.5
18	1.125-18 UNEF	16.2	23.1	11.4	19.2	25.6	27.0	35.0	3.2	15.8
20	1.250-18 UNEF	16.2	23.1	11.4	19.2	28.7	29.4	38.0	3.2	15.8
22	1.375-18 UNEF	16.2	23.1	11.4	19.2	31.9	31.8	41.0	3.2	15.8
24	1.500-18 UNEF	16.2	24.7	11.1	20.8	35.1	34.9	44.5	3.7	14.2
28	1.750-18 UNS	16.2	24.7	11.1	20.8	41.4	39.7	50.8	3.7	14.2
32	2.000-18 UNS	17.5	26.3	11.1	22.4	47.75	44.50	57.0	4.3	12.6
36	2.250-16 UN	17.5	26.3	11.1	22.4	52.5	49.2	63.5	4.3	12.6
40	2.500-16 UN	17.5	26.3	11.1	22.4	58.85	55.6	70.2	4.3	12.6

When insert includes A size "O" contact, increase "Z" by 8mm.



Series AC06A/MS3106A Series AC06R/MS3106R

Straight Plug

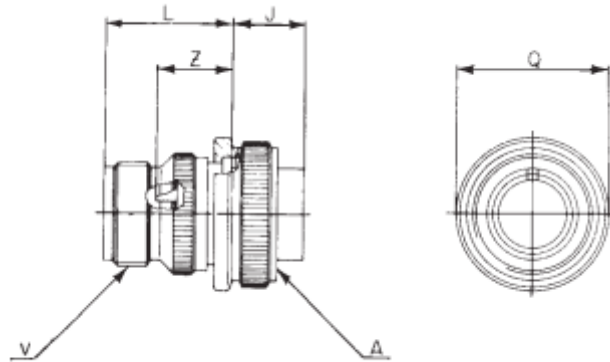

Dimensions in Inches

SHELL SIZE	A Thread Class 2B	J ± .004	L ± .020	Q ± .020	V Thread Class 2A	Z* ± .059
10SL	.625-24 UNEF	.531	1.043	.906	.625-24 UNEF	.571
14S	.875-20 UNEF	.531	1.043	1.102	.750-20 UNEF	.571
16S	1.000-20 UNEF	.531	1.043	1.240	.875-20 UNEF	.571
16	1.000-20 UNEF	.717	1.299	1.240	.875-20 UNEF	.815
18	1.125-18 UNEF	.717	1.299	1.343	1.000-20 UNEF	.815
20	1.250-18 UNEF	.717	1.299	1.469	1.1875-18 UNEF	.815
22	1.375-18 UNEF	.717	1.299	1.587	1.1875-18 UNEF	.815
24	1.500-18 UNEF	.717	1.350	1.713	1.4375-18 UNEF	.815
28	1.750-18 UNS	.717	1.665	1.945	1.4375-18 UNEF	.815
32	2.000-18 UNS	.717	1.799	2.213	1.750-18 UNS	.815
36	2.250-16 UN	.717	1.925	2.468	2.000-18 UNS	.815
40	2.500-16 UN	.717	1.925	2.717	2.250-16 UN	.815

When insert includes A size "O" contact, increase "Z" by .315 inch

Dimensions in Millimeters

SHELL SIZE	A Thread Class 2B	J ± .1	L ± .5	Q ± .5	V Class 2A	Z* ± 1.5
10SL	.625-24 UNEF	13.5	26.5	23.0	.625-24 UNEF	14.5
14S	.875-20 UNEF	13.5	26.5	28.0	.750-20 UNEF	14.5
16S	1.000-20 UNEF	13.5	26.5	31.5	.875-20 UNEF	14.5
16	1.000-20 UNEF	18.2	33.0	31.5	.875-20 UNEF	20.7
18	1.125-18 UNEF	18.2	33.0	34.1	1.000-20 UNEF	20.7
20	1.250-18 UNEF	18.2	33.0	37.3	1.1875-18 UNEF	20.7
22	1.375-18 UNEF	18.2	33.0	40.3	1.1875-18 UNEF	20.7
24	1.500-18 UNEF	18.2	34.3	43.5	1.4375-18 UNEF	20.7
28	1.750-18 UNS	18.2	42.3	49.4	1.4375-18 UNEF	20.7
32	2.000-18 UNS	18.2	45.7	56.2	1.750-18 UNS	20.7
36	2.250-16 UN	18.2	48.9	62.7	2.000-18 UNS	20.7
40	2.500-16 UN	18.2	48.9	69.0	2.250-16 UN	20.7

When insert includes A size "O" contact, increase "Z" by 8mm.

Series AC06F/MS3106F Straight Plug

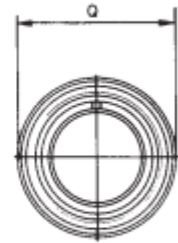
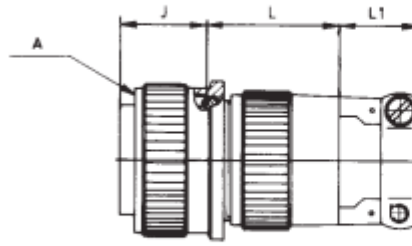

Dimensions in Inches

SHELL SIZE	A Thread Class 2B	J ± .004	L ± .020	L1 ± .008	Q ± .020
10SL	.625-24 UNEF	.531	1.043	.520	.906
14S	.875-20 UNEF	.531	1.043	.520	1.102
16S	1.000-20 UNEF	.531	1.043	.520	1.240
16	1.000-20 UNEF	.717	1.260	.531	1.240
18	1.125-18 UNEF	.717	1.240	.669	1.343
20	1.250-18 UNEF	.717	1.240	.669	1.469
22	1.375-18 UNEF	.717	1.240	.669	1.587
24	1.500-18 UNEF	.717	1.350	.768	1.713
28	1.750-18 UNS	.717	1.469	.768	1.965
32	2.000-18 UNS	.717	1.472	.768	2.213
36	2.250-16 UN	.717	1.354	1.083	2.468
40	2.500-16 UN	.717	1.354	1.083	2.717

Dimensions in Millimeters

SHELL SIZE	A Thread Class 2B	J + .1	L + .5	L1 + .2	Q + .5
10SL	.625-24 UNEF	13.5	26.5	13.2	23.0
14S	.875-20 UNEF	13.5	26.5	13.2	28.0
16S	1.000-20 UNEF	13.5	26.5	13.2	31.5
16	1.000-20 UNEF	18.2	32.0	13.5	31.5
18	1.125-18 UNEF	18.2	31.5	17.0	34.1
20	1.250-18 UNEF	18.2	31.5	17.0	37.3
22	1.375-18 UNEF	18.2	31.5	17.0	40.3
24	1.500-18 UNEF	18.2	34.3	19.5	43.5
28	1.750-18 UNS	18.2	37.3	19.5	49.9
32	2.000-18 UNS	18.2	37.4	19.5	56.2
36	2.250-16 UN	18.2	34.4	27.5	62.7
40	2.500-16 UN	18.2	34.4	27.5	69.0

Series AC08R/MS3108R Series AC08A/MS3108A

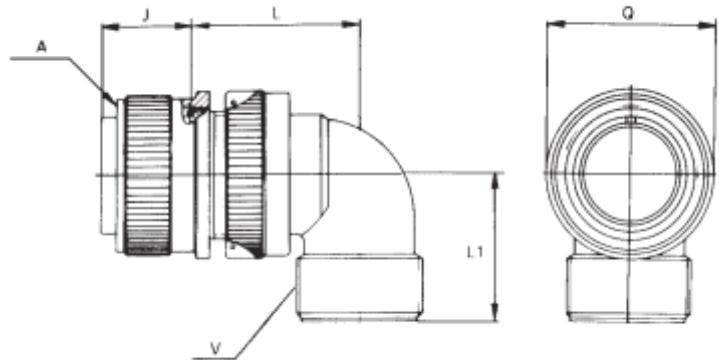

Dimensions in Inches

SHELL SIZE	A Thread Class 2B	J ± .004	L ± .020	L1 ± .020	Q ± .020	V Thread Class 2B
10SL	.625-24 UNEF	.531	.980	.945	.906	.625-24 UNEF
14S	.875-20 UNEF	.531	1.039	1.031	1.102	.750-20 UNEF
16S	1.000-20 UNEF	.531	1.169	1.094	1.240	.875-20 UNEF
16	1.000-20 UNEF	.717	1.370	1.094	1.240	.875-20 UNEF
18	1.125-18 UNEF	.717	1.476	1.189	1.343	1.000-20 UNEF
20	1.250-18 UNEF	.717	1.594	1.252	1.469	1.1875-18 UNEF
22	1.375-18 UNEF	.717	1.697	1.319	1.587	1.1875-18 UNEF
24	1.500-18 UNEF	.717	1.744	1.378	1.713	1.4375-18 UNEF
28	1.750-18 UNS	.717	1.835	1.476	1.965	1.4375-18 UNEF
32	2.000-18 UNS	.717	2.063	1.713	2.213	1.750-18 UNS
36	2.250-16 UN	.717	2.220	1.831	2.468	2.000-18 UNS
40	2.500-16 UN	.717	2.378	1.988	2.717	2.250-16 UN

Dimensions in Millimeters

SHELL SIZE	A Thread Class 2B	J ± .1	L ± .5	L1 ± .5	Q ± .5	V Thread Class 2B
10SL	.625-24 UNEF	13.5	24.9	24.0	23.0	.625-24 UNEF
14S	.875-20 UNEF	13.5	26.4	26.2	28.0	.750-20 UNEF
16S	1.000-20 UNEF	13.5	29.7	27.8	31.5	.875-20 UNEF
16	1.000-20 UNEF	18.2	34.8	27.8	31.5	.875-20 UNEF
18	1.125-18 UNEF	18.2	37.5	30.2	34.1	1.000-18 UNEF
20	1.250-18 UNEF	18.2	40.5	31.8	37.3	1.1875-18 UNEF
22	1.375-18 UNEF	18.2	43.1	33.5	40.3	1.1875-18 UNEF
24	1.500-18 UNEF	18.2	44.3	35.0	43.5	1.4375-18 UNEF
28	1.750-18 UNS	18.2	46.6	37.5	49.9	1.4375-18 UNEF
32	2.000-18 UNS	18.2	52.4	43.5	56.2	1.750-18 UNS
36	2.250-16 UN	18.2	56.4	46.5	62.7	2.000-18 UNS
40	2.500-16 UN	18.2	60.4	50.5	69.0	2.250-16 UN

Series AC08F/MS3108F

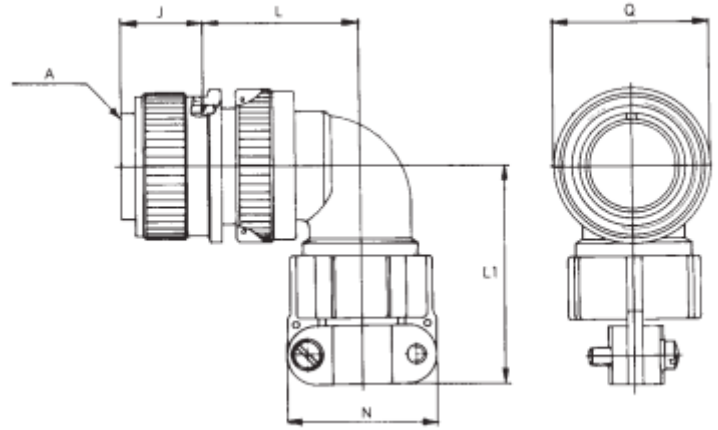

Dimensions in Inches

SHELL SIZE	A Thread Class 2B	J ± .004	L ± .020	L1 Max	N ± .031	Q ± .020
10SL	.625-24 UNEF	.531	.980	1.457	.878	.906
14S	.875-20 UNEF	.531	1.039	1.579	1.059	1.102
16S	1.000-20 UNEF	.531	1.169	1.689	1.157	1.240
16	1.000-20 UNEF	.717	1.370	1.689	1.157	1.240
18	1.125-18 UNEF	.717	1.476	1.780	1.252	1.343
20	1.250-18 UNEF	.717	1.594	1.862	1.469	1.469
22	1.375-18 UNEF	.717	1.697	1.929	1.469	1.587
24	1.500-18 UNEF	.717	1.744	2.083	1.689	1.713
28	1.750-18 UNS	.717	1.835	2.181	1.689	1.965
32	2.000-18 UNS	.717	2.063	2.339	2.031	2.213
36	2.250-16 UN	.717	2.220	2.535	2.280	2.468
40	2.500-16 UN	.717	2.378	3.189	2.689	2.717

Dimensions in Millimeters

SHELL SIZE	A Thread Class 2B	J ± .1	L ± .5	L1 Max	N ± .8	Q ± .5
10SL	.625-24 UNEF	13.5	24.9	37.0	22.3	23.0
14S	.875-20 UNEF	13.5	26.4	40.1	26.9	28.0
16S	1.000-20 UNEF	13.5	29.7	42.9	29.4	31.5
16	1.000-20 UNEF	18.2	34.8	42.9	29.4	31.5
18	1.125-18 UNEF	18.2	37.5	45.2	31.8	34.1
20	1.250-18 UNEF	18.2	40.5	47.3	37.3	37.3
22	1.375-18 UNEF	18.2	43.1	49.0	37.3	40.3
24	1.500-18 UNEF	18.2	44.3	52.9	42.9	43.5
28	1.750-18 UNS	18.2	46.6	55.4	42.9	49.9
32	2.000-18 UNS	18.2	52.4	59.4	51.6	56.2
36	2.250-16 UN	18.2	56.4	64.4	57.9	62.7
40	2.500-16 UN	18.2	60.4	81.0	68.3	69.0



Series AC-C Crimp Style Contacts

Commercial Version

CONTACT RATING

Contact Type (Size)	16	12	8	4	0
Rated Current, Max. A	22	41	73	135	245
Operating current, A	13	23	46	80	150
Test Current, A	20	35	60	110	200
Voltage Drop mV	35	30	25	20	20

VOLTAGE RATING

Symbol	I	A	D	E	B	C
Operating, V D.C.	250	700	1250	1750	2450	4200
Operating, V A.C.	200	500	900	1250	1750	3000
Test, V R.M.S.	1000	2000	2800	3500	4500	7000

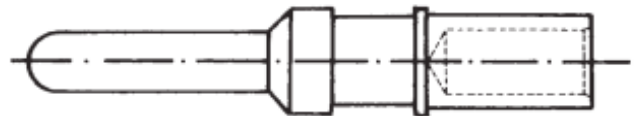
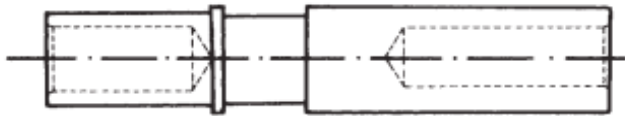

FEMALE

Part. No.	Size	Mm.2Cross Section	AWG
857-0657-130	16S	1 - 1.5	16
857-0658-130	16	1 - 1.5	16
857-0724-130	16	0.5	20
857-0725-130	16	2	14
857-0726-130	12	0.5	20
857-0727-130	12	1	18
857-0728-130	12	1.25 - 2	16 - 14
857-0730-130	12	2.5	2.5
857-0659-130	12	3	12
857-0731-130	12	4	4
857-0732-130	12	6	6
857-0641-130	8	9	8
857-0733-130	8	10	10
857-0663-130	4	22	4
857-0664-130	0	53	0

MALE

Part. No.	Size	Mm.2Cross Section	AWG
806-0645-130	16S	1 - 1.5	16
806-0646-130	16	1 - 1.5	16
806-0715-130	16	0.5	20
806-0716-130	16	2	14
806-0717-130	12	0.5	20
806-0718-130	12	1	18
806-0719-130	12	1.25 - 2	16 - 14
806-0720-130	12	2.5	2.5
806-0647-130	12	3	12
806-0721-130	12	4	4
806-0722-130	12	6	6
806-0648-130	8	9	8
806-0723-130	8	10	10
806-0649-130	4	22	4
806-0650-130	0	53	0

MS25043 Dust Caps for Receptacle Connectors (AC00/AC01/AC02)

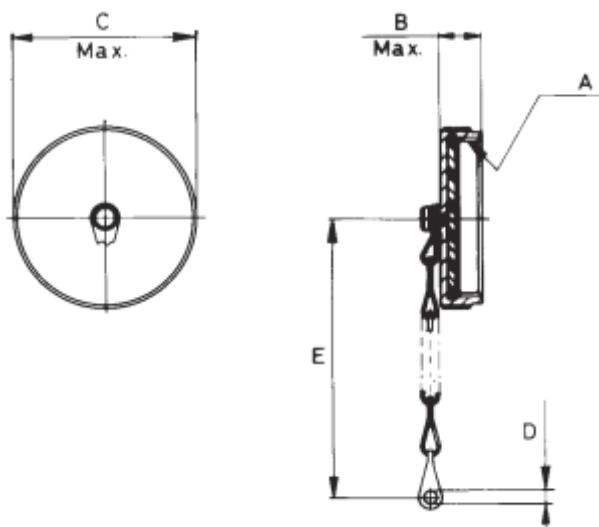

Dimensions in Inches

Part No.	Size	A	B ± .012	C ± .012	D	E
AC043-10 D	10SL	.625 - 24	.453	.791	.142	4.016
AC043-14 D	14 - 14S	.876 - 20	.453	1.059	.142	4.528
AC043-16 D	16 - 16S	1.000 - 20	.453	1.173	.142	4.528
AC043-18 D	18	1.125 - 18	.453	1.299	.142	4.528
AC043-20 D	20	1.250 - 18	.453	1.427	.142	5.000
AC043-22 D	22	1.375 - 18	.453	1.569	.142	5.000
AC043-24 D	24	1.500 - 18	.453	1.693	.167	5.512
AC043-28 D	28	1.750 - 18	.530	1.937	.167	7.756
AC043-32 D	32	2.000 - 18	.530	2.185	.189	7.756
AC043-36 D	36	2.250 - 16	.530	2.449	.189	7.756
AC043-40 D	40	2.500 - 16	.530	2.689	.189	7.756

Dimensions in Millimeters

Part No.	Size	A	B ± .3	C ± .3	D	E
AC043-10 D	10SL	.625 - 24	11.50	20.1	3.60	102
AC043-14 D	14 - 14S	.876 - 20	11.50	26.9	3.60	115
AC043-16 D	16 - 16S	1.000 - 20	11.50	29.8	3.60	115
AC043-18 D	18	1.125 - 18	11.50	33.0	3.60	115
AC043-20 D	20	1.250 - 18	11.50	36.25	3.60	127
AC043-22 D	22	1.375 - 18	11.50	39.85	3.60	127
AC043-24 D	24	1.500 - 18	11.50	43.0	4.25	140
AC043-28 D	28	1.750 - 18	13.45	49.2	4.25	197
AC043-32 D	32	2.000 - 18	13.45	55.5	4.80	197
AC043-36 D	36	2.250 - 16	13.45	62.2	4.80	197
AC043-40 D	40	2.500 - 16	13.45	68.3	4.80	197



MS25042 Dust Caps for Plug Connectors (AC06/AC08)

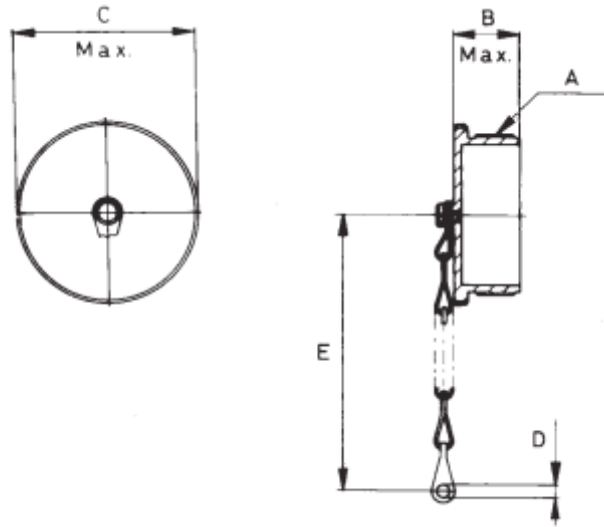

Dimensions in Inches

Part No.	Size	A	B± .012	C± .012	D	E
AC042-10 D	10SL	.625 - 24	.636	.681	.157	4.016
AC042-14 D	14 - 14S	.875 - 20	.823	.925	.157	4.528
AC042-16 D	16 - 16S	1.000 - 20	.823	1.055	.157	4.528
AC042-18 D	18	1.125 - 18	.823	1.181	.157	4.528
AC042-20 D	20	1.250 - 18	.823	1.291	.189	5.000
AC042-22 D	22	1.375 - 18	.823	1.429	.189	5.000
AC042-24 D	24	1.500 - 18	.823	1.555	.189	5.512
AC042-28 D	28	1.750 - 18	.823	1.803	.189	7.756
AC042-32 D	32	2.000 - 18	.823	2.055	.217	7.756
AC042-36 D	36	2.250 - 16	.823	2.303	.217	7.756
AC042-40 D	40	2.500 - 16	.823	2.551	.217	7.756

Dimensions in Millimeters

Part No.	Size	A	B± .3	C± .3	D	E
AC042-10 D	10SL	.625 - 24	16.15	17.3	4.0	102
AC042-14 D	14 - 14S	.875 - 20	20.9	23.5	4.0	115
AC042-16 D	16 - 16S	1.000 - 20	20.9	26.8	4.0	115
AC042-18 D	18	1.125 - 18	20.9	30.0	4.0	115
AC042-20 D	20	1.250 - 18	20.9	32.8	4.8	127
AC042-22 D	22	1.375 - 18	20.9	36.3	4.8	127
AC042-24 D	24	1.500 - 18	20.9	39.5	4.8	140
AC042-28 D	28	1.750 - 18	20.9	45.8	4.8	197
AC042-32 D	32	2.000 - 18	20.9	52.2	5.5	197
AC042-36 D	36	2.250 - 16	20.9	58.5	5.5	197
AC042-40 D	40	2.500 - 16	20.9	64.8	5.5	197

MS3057A

Cable Strain Relief Clamp

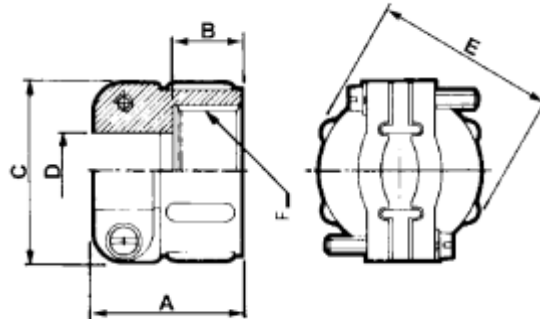
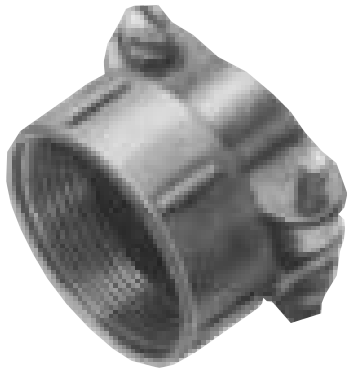

Dimensions in Inches

Part No.	Size	Used with Sleeve	A± .8	B	DMax	E-C± .8	F ThreadClass 2B
MS3057 - 4A	10SL - 12 - 12S	MS 3420 - 4	.811	.413	.315	.866	.625 -24 UNEF
MS3057 - 6A	14 - 14S	MS 3420 - 6	.874	.413	.433	1.063	.750 - 20 UNEF
MS3057 - 8A	16 - 16S	MS 3420 - 8	.945	.413	.559	1.142	.850 - 20 UNEF
MS3057 - 10A	18	MS 3420 - 10	.945	.413	.622	1.299	1.000 - 20 UNEF
MS3057 - 12A	20 - 22	MS 3420 - 12	.945	.413	.748	1.457	1.1875 - 18 NEF
MS3057 - 16A	24 - 28	MS 3420 - 16	1.024	.413	.937	1.693	1.4375 - 18 NEF
MS3057 - 20A	32	MS 3420 - 20	1.094	.429	1.252	2.031	1.750 - 18 NS
MS3057 - 24A	36	MS 3420 - 24	1.157	.531	1.378	2.283	2.000 - 18 NS
MS3057 - 28A	40	MS 3420 - 28	1.689	.531	1.626	2.689	2.250 - 16 UN

Dimensions in Millimeters

Part No.	Size	Used with Sleeve	A± .8	B	DMax	E-C± .8	F ThreadClass 2B
MS3057 - 4A	10SL - 12 - 12S	MS 3420 - 4	20.6	10.5	8.0	22.0	.625 -24 UNEF
MS3057 - 6A	14 - 14S	MS 3420 - 6	22.2	10.5	11.0	27.0	.750 - 20 UNEF
MS3057 - 8A	16 - 16S	MS 3420 - 8	24.0	10.5	14.2	29.0	.850 - 20 UNEF
MS3057 - 10A	18	MS 3420 - 10	24.0	10.5	15.8	33.0	1.000 - 20 UNEF
MS3057 - 12A	20 - 22	MS 3420 - 12	24.0	10.5	19.0	37.0	1.1875 - 18 NEF
MS3057 - 16A	24 - 28	MS 3420 - 16	26.0	10.5	23.8	43.0	1.4375 - 18 NEF
MS3057 - 20A	32	MS 3420 - 20	27.8	12.5	31.8	51.6	1.750 - 18 NS
MS3057 - 24A	36	MS 3420 - 24	29.4	13.5	35.0	58.0	2.000 - 18 NS
MS3057 - 28A	40	MS 3420 - 28	42.9	13.5	41.3	68.3	2.250 - 16 UN

MS3057B

Cable Strain Relief Clamp

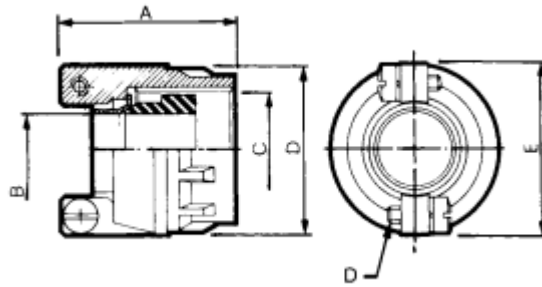

Dimensions in Inches

Part No.	Size	A± .02	B _{Open}	B _{Closed}	C ThreadClass 2B	D ThreadClass 2	E± .008	Used with Sleeve
MS3057 - 4B	10SL - 12 - 12S	1.272	.312	.094	.625 -24 UNEF	6 - 32 NC	.890	MS 3420 - 4A
MS3057 - 6B	14 - 14S	1.272	.438	.230	.750 - 20 UNEF	6 - 32 NC	1.016	MS 3420 - 6A MS 3420 - 4A
MS3057 - 8B	16 - 16S	1.272	.531	.315	.850 - 20 UNEF	6 - 32 NC	1.106	MS 3420 - 8A MS 3420 - 6A
MS3057 - 10B	18	1.390	.625	.378	1.000 - 20 UNE	6 - 32 NC	1.220	MS 3420 - 10A MS 3420 - 6A
MS3057 - 12B	20 - 22	1.406	.748	.445	1.1875 - 18 NEF	8 - 32 NC	1.469	MS 3420 - 12A MS 3420 - 8A
MS3057 - 16B	24 - 28	1.516	.937	.610	1.4375 - 18 NEF	8 - 32 NC	1.654	MS 3420 - 16AMS 3420 - 12AMS 3420 - 8A
MS3057 - 20B	32	1.772	1.252	.937	1.750 - 18 NS	250 - 20 NC	2.165	MS 3420 - 20AMS 3420 - 16AMS 3420 - 12A
MS3057 - 24B	36	2.024	1.374	.969	2.000 - 18 NS	250 - 20 NC	2.283	MS 3420 - 24AMS 3420 - 18AMS 3420 - 16A
MS3057 - 28B	40	2.024	1.626	1.189	2.250 - 16 UN	250 - 20	2.539	MS 3420 - 28AMS 3420 - 20AMS 3420 - 16A

Dimensions in Millimeters

Part No.	Size	A± .5	B _{Open}	B _{Closed}	C ThreadClass 2B	D ThreadClass 2	E± .2	Used with Sleeve
MS3057 - 4B	10SL - 12 - 12S	32.3	7.93	2.38	.625 -24 UNEF	6 - 32 NC	22.6	MS 3420 - 4A
MS3057 - 6B	14 - 14S	32.3	11.12	5.84	.750 - 20 UNEF	6 - 32 NC	25.8	MS 3420 - 6A MS 3420 - 4A
MS3057 - 8B	16 - 16S	32.3	13.48	8.0	.850 - 20 UNEF	6 - 32 NC	28.1	MS 3420 - 8A MS 3420 - 6A
MS3057 - 10B	18	35.3	15.87	9.6	1.000 - 20 UNE	6 - 32 NC	31.0	MS 3420 - 10A MS 3420 - 6A
MS3057 - 12B	20 - 22	35.7	19.0	11.3	1.1875 - 18 NEF	8 - 32 NC	37.3	MS 3420 - 12A MS 3420 - 8A
MS3057 - 16B	24 - 28	38.5	23.8	15.5	1.4375 - 18 NEF	8 - 32 NC	42.0	MS 3420 - 16AMS 3420 - 12AMS 3420 - 8A
MS3057 - 20B	32	45.0	31.8	23.8	1.750 - 18 NS	250 - 20 NC	55.0	MS 3420 - 20AMS 3420 - 16AMS 3420 - 12A
MS3057 - 24B	36	51.4	34.9	24.6	2.000 - 18 NS	250 - 20 NC	58.0	MS 3420 - 24AMS 3420 - 18AMS 3420 - 16A
MS3057 - 28B	40	51.4	41.3	30.2	2.250 - 16 UN	250 - 20	64.5	MS 3420 - 28AMS 3420 - 20AMS 3420 - 16A

+1 305.234.1000
cinch.com

MS3057C

Cable Strain Relief Clamp

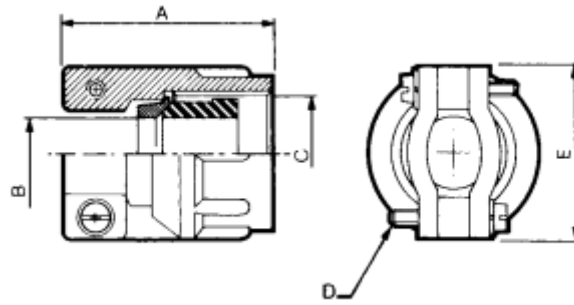

Dimensions in Inches

Part No.	Size	A± .02	B _{Open}	B _{Closed}	C ThreadClass 2B	D ThreadClass 2	E± .008	Used with Sleeve
MS3057 - 4C	10SL - 12 - 12S	1.272	.312	.094	.625 - 24 UNEF	6 - 32 NC	.890	MS 3420 - 4A
MS3057 - 6C	14 - 14S	1.272	.438	.230	.750 - 20 UNEF	6 - 32 NC	1.016	MS 3420 - 6A MS 3420 - 4A
MS3057 - 8C	16 - 16S	1.272	.531	.315	.850 - 20 UNEF	6 - 32 NC	1.106	MS 3420 - 8A MS 3420 - 6A
MS3057 - 10C	18	1.390	.625	.378	1.000 - 18 UNE	6 - 32 NC	1.220	MS 3420 - 10A MS 3420 - 6A
MS3057 - 12C	20 - 22	1.406	.748	.445	1.1875 - 18 NEF	8 - 32 NC	1.469	MS 3420 - 12A MS 3420 - 8A
MS3057 - 16C	24 - 28	1.516	.937	.610	1.4375 - 18 NEF	8 - 32 NC	1.654	MS 3420 - 16AMS 3420 - 12AMS 3420 - 8A
MS3057 - 20C	32	1.772	1.245	.937	1.750 - 18 NS	250 - 20 NC	2.165	MS 3420 - 20AMS 3420 - 16AMS 3420 - 12A
MS3057 - 24C	36	2.024	1.374	.969	2.000 - 18 NS	250 - 20 NC	2.283	MS 3420 - 24AMS 3420 - 18AMS 3420 - 16A
MS3057 - 28C	40	2.024	1.626	1.189	2.250 - 16 UN	250 - 20	2.539	MS 3420 - 28AMS 3420 - 20AMS 3420 - 16A

Dimensions in Millimeters

Part No.	Size	A±0.5	B _{Open}	B _{Closed}	C ThreadClass 2B	D ThreadClass 2	E±0.2	Used with Sleeve
MS3057 - 4C	10SL - 12 - 12S	32.3	7.93	2.38	.625 - 24 UNEF	6 - 32 NC	22.6	MS 3420 - 4A
MS3057 - 6C	14 - 14S	32.3	11.12	5.84	.750 - 20 UNEF	6 - 32 NC	25.8	MS 3420 - 6A MS 3420 - 4A
MS3057 - 8C	16 - 16S	32.3	13.48	8.00	.850 - 20 UNEF	6 - 32 NC	28.1	MS 3420 - 8A MS 3420 - 6A
MS3057 - 10C	18	35.3	15.87	9.60	1.000 - 18 UNE	6 - 32 NC	31.0	MS 3420 - 10A MS 3420 - 6A
MS3057 - 12C	20 - 22	35.7	19.0	11.30	1.1875 - 18 NEF	8 - 32 NC	37.3	MS 3420 - 12A MS 3420 - 8A
MS3057 - 16C	24 - 28	38.5	23.8	15.50	1.4375 - 18 NEF	8 - 32 NC	42.0	MS 3420 - 16AMS 3420 - 12AMS 3420 - 8A
MS3057 - 20C	32	45.0	31.75	23.80	1.750 - 18 NS	250 - 20 NC	55.0	MS 3420 - 20AMS 3420 - 16AMS 3420 - 12A
MS3057 - 24C	36	51.4	34.9	24.60	2.000 - 18 NS	250 - 20 NC	58.0	MS 3420 - 24AMS 3420 - 18AMS 3420 - 16A
MS3057 - 28C	40	51.4	41.3	30.20	2.250 - 16 UN	250 - 20	64.5	MS 3420 - 28AMS 3420 - 20AMS 3420 - 16A

Accessories - MS3420 Neoprene Sleeves and Sealing Plugs

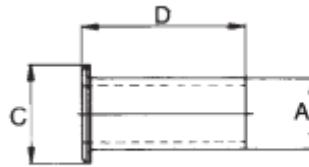
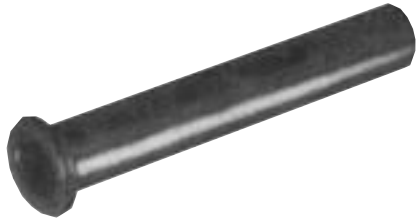

Dimensions in Inches

Part No.	Used with Cable Clamp	A	B	C	D
MS 3420 - 3	3057 - 3A	.209	.130	.374	2.874
MS 3420 - 4	3057 - 4A	.299	.130	.504	2.756
MS 3420 - 6	3057 - 6A	.425	.130	.618	2.638
MS 3420 - 8	3057 - 8A	.551	.437	.740	2.520
MS 3420 - 10	3057 - 10A	.614	.563	.866	2.402
MS 3420 - 12	3057 - 12A	.740	.626	1.059	2.244
MS 3420 - 16	3057 - 16A	.925	.752	1.059	2.087
MS 3420 - 20	3057 - 20A	1.240	.937	1.594	1.969
MS 3420 - 24	3057 - 24A	1.362	1.252	1.850	1.850
MS 3420 - 28	3057 - 28A	1.614	1.378	2.087	1.732

Dimensions in Millimeters

Part No.	Used with Cable Clamp	A	B	C	D
MS 3420 - 3	3057 - 3A	5.30	3.30	9.50	73.0
MS 3420 - 4	3057 - 4A	7.60	5.60	12.8	70.0
MS 3420 - 6	3057 - 6A	10.8	7.90	15.7	67.0
MS 3420 - 8	3057 - 8A	14.0	11.1	18.8	64.0
MS 3420 - 10	3057 - 10A	15.6	14.3	22.0	61.0
MS 3420 - 12	3057 - 12A	18.8	15.9	26.9	57.0
MS 3420 - 16	3057 - 16A	23.5	19.1	33.3	53.0
MS 3420 - 20	3057 - 20A	31.5	23.8	40.5	50.0
MS 3420 - 24	3057 - 24A	34.6	31.8	47.0	47.0
MS 3420 - 28	3057 - 28A	41.0	35.0	53.0	44.0



Part No.	Contact Size	Color
999-0228-020	20	Red
999-0228-016	16	Blue
999-0228-012	12	Yellow
999-0228-008	8	White
999-0228-004	4	Green
999-0228-000	0	Black

Accessories - Gaskets (AC00/MS3100, AC01/MS3101 and AC02/MS3102)

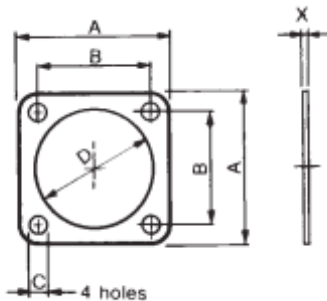
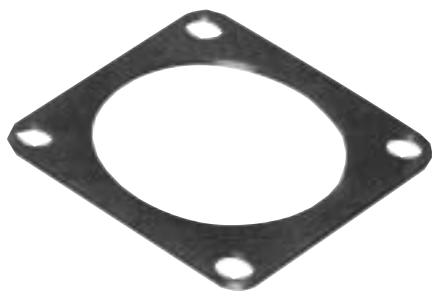

$X = 0.95 \pm 0.05$

Polychloroprene gasket for panel moisture proofing. Used with connector types AC00/MS3100 and AC02/MS3102

$X = 0.7 \pm 0.01$

Polychloroprene conductive gasket for panel moisture proofing and to ensure electrical continuity. Used with same types as std.

Dimensions in Inches

Std. Code	Size	A± .020	B± .020	C± .020	D± .020	Conductive Gasket Code
904-0045-010	10SL	.937	.719	.130	.626	904-0047-010
904-0045-012	12 - 12S	1.031	.811	.130	.752	904-0047-012
904-0045-014	14 - 14S	1.266	.906	.130	.878	904-0047-014
904-0045-016	16 - 16S	1.220	.969	.130	1.004	904-0047-016
904-0045-018	18	1.311	1.063	.130	1.126	904-0047-018
904-0045-020	20	1.437	1.156	.130	1.252	904-0047-020
904-0045-022	22	1.563	1.250	.130	1.378	904-0047-022
904-0045-024	24	1.689	1.374	.157	1.504	904-0047-024
904-0045-028	28	1.968	1.563	.197	1.752	904-0047-028
904-0045-032	32	2.244	1.750	.197	2.008	904-0047-032
904-0045-036	36	2.480	1.937	.197	2.205	904-0047-036
904-0045-040	40	2.717	2.187	.197	2.441	904-0047-040

Dimensions in Millimeters

Std. Code	Size	A± .5	B± .5	C± .5	D± .5	Conductive Gasket Code
904-0045-010	10SL	23.8	18.25	3.3	15.9	904-0047-010
904-0045-012	12 - 12S	26.2	20.60	3.3	19.1	904-0047-012
904-0045-014	14 - 14S	28.6	23.00	3.3	22.3	904-0047-014
904-0045-016	16 - 16S	31.0	24.60	3.3	25.5	904-0047-016
904-0045-018	18	33.3	27.00	3.3	28.6	904-0047-018
904-0045-020	20	36.5	29.35	3.3	31.8	904-0047-020
904-0045-022	22	39.7	31.75	3.3	35.0	904-0047-022
904-0045-024	24	42.9	34.90	4.0	38.2	904-0047-024
904-0045-028	28	50.0	39.70	5.0	44.5	904-0047-028
904-0045-032	32	57.0	44.45	5.0	51.0	904-0047-032
904-0045-036	36	63.0	49.20	5.0	56.0	904-0047-036
904-0045-040	40	69.0	55.55	5.0	62.0	904-0047-040

Other Quality Connectors



QPL'd MIL-C-5015 &
Special Connectors
for Commercial Applications

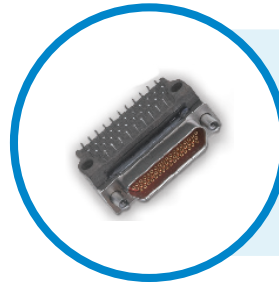

Dura-Con
Microminiature-D Connectors



QPL'd MIL-C-26482 Series I
Solder and Crimp Connectors



Quick Disconnect Connectors
Solder and Crimp Types



Mini-D "MD" Connectors



Expanded Beam Fiber
Optics



Filtered Connectors
Solder and Crimp Connectors

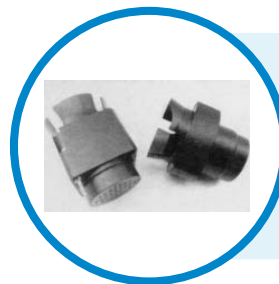

Special Cryogenic
Connectors



Omega
MIL-C-26500 - Cylindrical Connectors



Rugged Acme Thread
Connectors
for Industrial Electrical Equipment



Proven Excellence

In operation since 1917, Cinch supplies high quality, high performance connectors and cables globally to the Aerospace, Military/Defense, Commercial Transportation, Oil & Gas, High End Computer, and other markets. We provide custom solutions with our creative, hands on engineering and end to end approach.

Our diverse product offerings include: connectors, enclosures and cable assemblies utilizing multiple contact technologies including copper and fiber optics. Our product engineering and development activities employ cutting edge technologies for design and modeling, and our various technologies and expertise enable us to deliver custom solutions and products for our strategic partnerships. We also serve a broad range of commercial markets, largely through our highly efficient distribution network.

We aim to exceed our customer's expectations, and to continually provide innovative solutions to the rapidly changing needs of the markets, and customers, we serve.

Cinch Connectivity Solutions

Cinch Connectivity Solutions
12400-8 S.W. 134th Court
Miami, Florida 33186 USA
+1 305.234 1000
inquiry@cinch.com
cinch.com

